

Pneumatic External Concrete Vibrators VAQ Series



- Rotary Vibration
- Force 11000 N to 60000 N
- Variable Force / Frequency by air pressure
- Quick Release

TECHNICAL CHARACTERISTICS

TYPE	VAQ 1000	VAQ 1400	VAQ 2500	VAQ 2700	VAQ 4000	VAQ 4000S	VAQ 4500	VAQ 6000
C' Force (N)	11000	14250	25000	27000	40000	40000	45000	60000
Working Moment (cm kg)	0.75	1.02	3.5	1.95	2.96	5.51	9.5	5.4
Frequency (v.p.m.)	16500	16000	9000	16000	15200	10200	8500	14500
Air / con (L/m)	1100	1200	1600	1600	1800	1800	1800	1800
Weight (kgs)	7.2	7.3	15	14	14.5	18	17.6	16.3
Weld-on Bracket	QR2	QR2	QR4	QR4	QR4	QR4	QR4	QR4

NOTE : Special silenced version VAQ4000S has noise level of 90 dBA.
Performance data established in free air with a supply pressure of 6 bar (87 P.S.I.)

VAQ 1000 - 1400 fitted to QR2 bracket

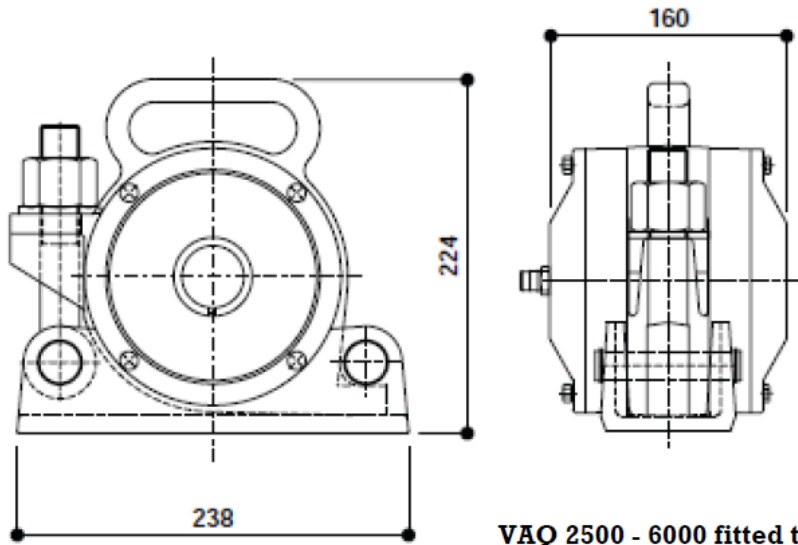
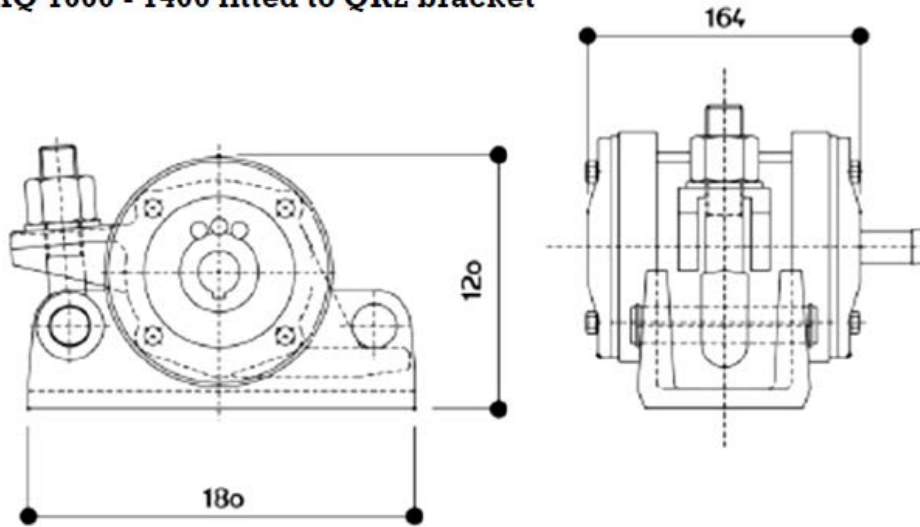

VAQ 2500 - 6000 fitted to QR4 bracket

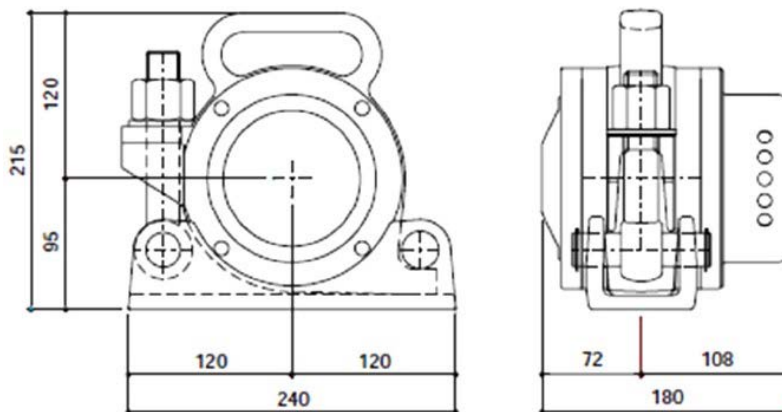

VAQ4000S Silenced fitted to QR4 bracket