

PNEUMATIC NUTRUNNERS

Atlas Copco



Introduction – Pneumatic Nutrunners

User-friendly tools offering power, speed and accuracy

The tools in Atlas Copco's broad range of pneumatic nutrunners offer a superior combination of power, speed and accuracy. With their advanced ergonomic designs, they are also extremely user-friendly and will contribute to raising productivity in a wide range of applications in your assembly plant.

Tools in Atlas Copco's range of pneumatic nutrunners are divided into three main categories: Angle, straight and pistol grip versions. These are also available in optional models, such as crowfoot, hold-and-drive, and flush socket.

THE POWER TO RAISE PRODUCTIVITY

The high power output provided by Atlas Copco nutrunners is decisive for productivity, i.e., the combined performance of operator and tool. The tools are set at the optimal speed for every torque capacity rating. The balance between speed and clutch response gives high accuracy, ensuring torque repeatability, regardless of joint characteristics.

COMFORTABLE TO WORK WITH

Our pneumatic nutrunners live up to Atlas Copco's reputation for developing tools with good ergonomics. Low tool weights, thermally insulated grips and low noise and vibration levels all help to reduce operator fatigue and raise individual productivity in your plant.

Simplicity in selection and installation allow you to set the torque once and that is the torque you will get, joint after joint, without complicated analyses.

CHOOSING THE RIGHT TOOL IS EASY

No joint is too complicated for a nutrunner. To set the torque, just adjust it to the required level, regardless of joint conditions.



A new angle on productivity

The LTV 9-2 and LTV 8 angle nutrunner range from Atlas Copco successfully combines two key performance factors – speed and accuracy. Consistently accurate, high-speed tightening is complemented by advanced ergonomic design, ensuring an unmatched level of productivity. All this is presented in a tool that is very easy to handle.

Angle nutrunners from Atlas Copco are certified for accuracy and durability by major car manufacturers. They are easy to choose, easy to set, and easy to operate.

ACCURATE EVERY TIME

Hard or soft joint? You don't need to think about it. The tool gives the torque you install, independent of joint variations and variations in air pressure and lubrication. The clutch shuts off at the same torque, tightening after tightening.

HIGHEST PRODUCTIVITY

Instant disengagement of the clutch keeps torque over-shoot to a minimum even on the fastest tools. Our new models were developed to meet the most extreme requirements on operational speeds.

As always, we kept operator comfort in mind. The tools are well balanced, slim and comfortable to handle. Reaction forces are extremely low.

JOB VERIFICATION

For remote indication of clutch release function the tools can be equipped with air signal outlet – RE. This is often used for counting the number of fasteners in a tightening cycle.



Shut-off

Angle Nutrunners

LTV29-2 SERIES

- Designed for high speed and small dimensions.
- Slim lightweight design.
- Soft, comfortable grip.
- Easy to reverse.
- Low reaction force.
- Spiral cut angle gears.



LTV29-2

LTV39-2 SERIES

- The fastest nutrunners of this type.
- Powerful motor.
- Consistently high accuracy.
- Many operator-friendly features.
- Spiral cut angle gears.



LTV39-2

LTV FS FLUSH SOCKET TOOLS

- Minimum angle head size gives good access.
- High torque accuracy.
- Integrated sockets give reduced angle head height.
- Spiral cut angle gears.

Model	Bolt size mm	Square drive in	Torque range soft joint		Free speed r/min	Weight		Length mm	Angle head height mm	Angle head center to side mm	Air consumption at free speed		Rec. hose size mm	Air inlet thread in	Ordering No.
			Nm	ft lb		kg	lb				l/s	cfm			
Reversible															
LTV29-2 R12-6	M6	1/4	6-12	4.5-9	850	1.3	2.9	351	27	11	10	21	10	1/4	8431 0631 15
LTV29-2 R12-10	M6	3/8	6-12	4.5-9	850	1.3	2.9	351	27	11	10	21	10	1/4	8431 0631 16
LTV29-2 R12-Q	M6	1/4 ^a	6-12	4.5-9	850	1.3	2.9	351	44	11	10	21	10	1/4	8431 0631 17
LTV29-2 R12-42	M6	1/4 ^b	6-12	4.5-9	850	1.3	2.9	351	34	11	10	21	10	1/4	8431 0631 18
LTV29-2 R12-B6	M6	1/4	6-12	4.5-9	850	1.3	2.9	351	27	11	10	21	10	1/4	8431 0631 00
LTV29-2 R12-B10	M6	3/8	6-12	4.5-9	850	1.3	2.9	351	27	11	10	21	10	1/4	8431 0631 01
LTV29-2 R16-6	M6	1/4	9-16	7-12	850	1.3	2.9	351	27	11	10	21	10	1/4	8431 0631 22
LTV29-2 R16-10	M6	3/8	9-16	7-12	850	1.3	2.9	351	27	11	10	21	10	1/4	8431 0631 21
LTV29-2 R16-Q	M6	1/4 ^a	9-16	7-12	850	1.3	2.9	351	44	11	10	21	10	1/4	8431 0631 24
LTV29-2 R16-42	M6	1/4 ^b	9-16	7-12	850	1.3	2.9	351	34	11	10	21	10	1/4	8431 0631 23
LTV29-2 R16-B6	M6	1/4	9-16	7-12	850	1.3	2.9	351	27	11	10	21	10	1/4	8431 0631 02
LTV29-2 R16-B10	M6	3/8	9-16	7-12	850	1.3	2.9	351	27	11	10	21	10	1/4	8431 0631 03
LTV29-2 R24-10	M8	3/8	12-24	9-18	640	1.4	3.1	374	30	14	10	21	10	1/4	8431 0631 29
LTV29-2 R24-B10	M8	3/8	12-24	9-18	640	1.4	3.1	374	30	14	10	21	10	1/4	8431 0631 04
LTV29-2 R30-10	M8	3/8	15-30	11-22	500	1.4	3.1	374	30	14	10	21	10	1/4	8431 0631 37
LTV29-2 R30-B10	M8	3/8	15-30	11-22	500	1.4	3.1	374	30	14	10	21	10	1/4	8431 0631 36
LTV39-2 R16-10	M6	3/8	7-16	5-12	1200	1.5	3.3	375	27	11	16	34	10	1/4	8431 0633 09
LTV39-2 R16-B10	M6	3/8	7-16	5-12	1200	1.5	3.3	375	27	11	16	34	10	1/4	8431 0631 05
LTV39-2 R24-B10	M8	3/8	12-24	9-18	870	1.6	3.5	385	30	14	16	34	10	1/4	8431 0631 06
LTV39-2 R30-10	M8	3/8	15-30	11-22	870	1.6	3.5	385	35	14	16	34	10	1/4	8431 0633 19
LTV39-2 R30-B10	M8	3/8	15-30	11-22	870	1.6	3.5	385	35	14	16	34	10	1/4	8431 0631 07
LTV39-2 R37-10	M8	3/8	22-37	16-27	708	1.7	3.7	405	35	18	16	34	10	1/4	8431 0633 24
LTV39-2 R37-B10	M8	3/8	22-37	16-27	708	1.7	3.7	405	35	18	16	34	10	1/4	8431 0631 08
LTV39-2 R48-10	M8	3/8	24-48	18-35	560	1.7	3.7	405	35	18	16	34	10	1/4	8431 0633 27
LTV39-2 R48-13	M8	1/2	24-48	18-35	560	2.0	4.4	425	41	20	16	34	10	1/4	8431 0633 43
LTV39-2 R48-B10	M8	3/8	24-48	18-35	560	1.7	3.7	405	35	18	16	34	10	1/4	8431 0631 09
LTV39-2 R48-B13	M8	1/2	24-48	18-35	560	2.0	4.4	425	41	20	16	34	10	1/4	8431 0631 10
LTV39-2 R56-10	M10	3/8	28-56	21-41	460	1.7	3.7	405	35	18	16	34	10	1/4	8431 0633 35
LTV39-2 R56-13	M10	1/2	28-56	21-41	460	2.0	4.4	425	41	20	16	34	10	1/4	8431 0633 51
LTV39-2 R56-B10	M10	3/8	28-56	21-41	460	1.7	3.7	405	35	18	16	34	10	1/4	8431 0631 11
LTV39-2 R56-B13	M10	1/2	28-56	21-41	460	2.0	4.4	425	41	20	16	34	10	1/4	8431 0631 12
LTV39-2 R70-13	M10	1/2	35-70	26-51	350	2.1	4.6	425	41	20	16	34	10	1/4	8431 0633 59
LTV39-2 R70-B13	M10	1/2	35-70	26-51	350	2.1	4.6	425	41	20	16	34	10	1/4	8431 0631 13
LTV39-2 R85-13	M10-12	1/2	43-85	32-63	305	2.5	5.5	500	52	25	16	34	10	1/4	8431 0633 67
LTV39-2 R85-B13	M10-12	1/2	43-85	32-63	305	2.5	5.5	500	52	25	16	34	10	1/4	8431 0631 14
LTV39-2 R120-13	M12	1/2	60-120	44-88	220	2.5	5.5	500	52	25	16	34	10	1/4	8431 0633 69
Flush socket															
LTV29-2 R24 FS	M8	–	12-24	9-18	640	1.4	3.7	357	32	15	10	21	10	1/4	8431 0634 51
LTV29-2 R30 FS	M8	–	15-30	11-22	500	1.3	3.1	357	32	15	10	21	10	1/4	8431 0634 52
LTV39-2 R37 FS	M8	–	22-37	16-27	708	1.7	3.7	406	38	19	16	34	10	1/4	8431 0634 53
LTV39-2 R48 FS	M8	–	24-48	18-35	560	1.7	3.7	406	38	19	16	34	10	1/4	8431 0634 54
LTV39-2 R56 FS	M8	–	28-56	21-41	460	1.7	3.7	406	38	19	16	34	10	1/4	8431 0634 55
LTV39-2 R70 FS	M10	–	35-70	26-51	350	2.1	4.6	425	50	20	16	34	10	1/4	8431 0634 56
LTV39-2 R85 FS	M10-12	–	43-85	32-63	305	2.5	5.5	500	58	26	16	34	10	1/4	8431 0634 57
LTV39-2 R120 FS	M12	–	60-120	44-88	220	2.5	5.5	500	58	26	16	34	10	1/4	8431 0634 58

^a Quick change chuck. ^b Female hex drive. B - Ball retainer

Shut-off

Angle Nutrunners

LTV28 AND 38 SERIES

- Highest reliability when tightening M5-M12 screws.
- Small, durable gears.
- Precise clutch.
- Reliable motor.
- Spiral cut angle gears.



LTV48 SERIES

- Robust, reliable tools.
- Reversible for torques up to 200 Nm.
- Comfortable to operate due to low weight and smooth handles.
- Reaction bars and other accessories available.
- Spiral cut angle gears.



LTV FS FLUSH SOCKET TOOLS

- Minimum angle head size gives good access.
- High torque accuracy.
- Integrated sockets give reduced angle head height.
- Spiral cut angle gears.



Model	Bolt size mm	Square drive in	Torque range soft joint		Free speed r/min	Weight		Length mm	Angle head height mm	Angle head center to side mm	Air consumption at free speed		Rec. hose size mm	Air inlet thread in	Ordering No.
			Nm	ft lb		kg	lb				l/s	cfm			
Reversible															
LTV28 R07-6	M5	1/4	2.5-7	1.8-5	1100	1.3	2.9	334	28.5	10	8	17	8	1/4	8431 0601 65
LTV28 R07-42	M5	1/4 ^a	2.5-7	1.8-5	1100	1.3	2.9	334	28.5	10	8	17	8	1/4	8431 0601 73
LTV28 R07-Q	M6	1/4 ^b	2.5-7	1.8-5	1100	1.3	2.9	334	28.5	10	8	17	8	1/4	8431 0601 68
LTV28 R15-6	M6	1/4	7-15	5-11	560	1.4	3.1	349	28	11	10	21	10	1/4	8431 0601 52
LTV28 R15-10	M6	3/8	7-15	5-11	560	1.4	3.1	349	28	11	10	21	10	1/4	8431 0601 55
LTV28 R15-Q	M6	1/4 ^b	7-15	5-11	560	1.4	3.1	349	28	11	10	21	10	1/4	8431 0601 53
LTV28 R20-10	M6	3/8	10-19	7-15	530	1.4	3.1	355	34.5	13.5	10	21	10	1/4	8431 0601 50
LTV28 R20-42	M6	1/4 ^a	10-20	7-15	420	1.4	3.1	350	34	13.5	10	21	10	1/4	8431 0601 48
LTV28 R28-10	M8	3/8	14-28	10-21	340	1.4	3.1	350	29.5	13.5	10	21	10	1/4	8431 0601 40
LTV28 R28-42	M8	1/4 ^a	14-28	10-21	340	1.4	3.1	350	29.5	13.5	10	21	10	1/4	8431 0601 44
LTV28 RL28-10	M8	3/8	14-28	10-21	80	1.4	3.1	350	29.5	13.5	10	21	10	1/4	8431 0601 33
LTV38 R42-10	M8	3/8	20-42	15-31	400	2.0	4.4	436	34.5	18	16	34	10	1/4	8431 0603 55
LTV38 R42-13	M8	1/2	20-42	15-31	400	2.2	4.8	453	41	20	16	34	10	1/4	8431 0603 69
LTV38 R50-10	M10	3/8	25-50	18-36	330	2.0	4.4	436	34.5	18	16	34	10	1/4	8431 0603 63
LTV38 R50-13	M10	1/2	25-50	18-36	330	2.2	4.8	453	41	20	16	34	10	1/4	8431 0603 71
LTV38 R57-13	M10	1/2	30-57	22-41	280	2.2	4.8	453	41	20	16	34	10	1/4	8431 0603 51
LTV38 R70-13	M10	1/2	34-70	24-50	225	2.4	5.3	487	41	20	16	34	10	1/4	8431 0603 46
LTV38 R85-13	M10-12	1/2	40-85	29-61	190	2.8	6.1	530	52	25	16	34	10	1/4	8431 0603 38
LTV48 R120-L13	M12	1/2	70-120	51-88	215	3.5	7.6	590	52	25	28	59	12.5	1/2	8431 0534 88
LTV48 R150-L13	M12	1/2	70-150	51-111	170	3.5	7.6	590	52	25	28	59	12.5	1/2	8431 0534 93
LTV48 R200-L13	M14	1/2	115-200	85-148	100	3.8	8.3	610	52	25	28	59	12.5	1/2	8431 0534 98
Flush socket															
LTV48 R150 FS	M12	–	70-150	44-111	180	3.5	7.6	590	70	25	28	59	12.7	1/2	8431 0610 17
LTV48 R200 FS	M14	–	115-200	85-148	100	3.8	8.3	610	70	25	28	59	12.8	1/2	8431 0610 21

^a Female hex drive.

^b Quick change chuck.

Shut-off

Angle Nutrunners

LTV69 SERIES

- New twin motor – higher rundown speed, accurate tightening.
- High torques.
- Good access in cramped spaces.
- Spiral cut angle gears.



Model	Bolt size mm	Square drive in	Min torque at 3 bar soft joint		Min torque at 6.3 bar soft joint		Max torque at 6.3 bar soft joint		Free speed r/min	Weight		Length mm	Angle head height mm	Angle head center to side mm	Air consumption at free speed		Rec. hose size mm	Air inlet thread in	Ordering No.
			Nm	ft lb	Nm	ft lb	Nm	ft lb		kg	lb				l/s	cfm			
Reversible																			
LTV69 R180-13 ^a	M16	1/2	70	52	100	74	170	125	840	5.1	11.1	592	50	25.3	20	42	13	1/2	8431 0830 04
LTV69 R370-20 ^a	M18	3/4	140	103	190	140	370	273	480	7.6	16.6	634	62	32.9	20	42	13	1/2	8431 0830 15
LTV69 R600-25 ^a	M22	1	230	170	400	295	600	443	280	10.2	22.6	676	77	54.0	20	42	13	1/2	8431 0830 21
Non-reversible																			
LTV69 N180-13	M16	1/2	70	52	100	74	170	125	840	4.6	10.1	577	50	25.3	20	42	13	1/2	8431 0830 35
LTV69 N370-20	M18	3/4	140	103	190	140	370	273	480	7.1	15.6	619	62	32.9	20	42	13	1/2	8431 0830 46
LTV69 N600-25	M22	1	230	170	400	295	600	443	280	9.7	21.3	661	77	54.0	20	42	13	1/2	8431 0830 52

^a Fixed reverse.

Crowfoot Type

Angle Nutrunners

IN-LINE CROWFOOT TOOLS

Dimensions

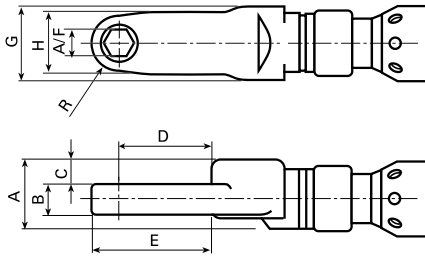

LTC

Model	Torque		Speed r/min	Weight		Length mm	A/F mm	A mm	B mm	C mm	D mm	E mm	G mm	H mm	R mm	Ordering No.
	Nm	ft lb		kg	lb											
LTC009 R08-10-LI3	4-8	2.9-6	210	1.3	2.9	312	10	34	10	13.5	37	41	35	22	10	8431 0613 72
LTC009 R13-10-LI3	6-13	4-9	127	1.8	4	312	10	34	15	12.5	46.7	59.2	35	22	10	8431 0616 01
LTC009 R14-12-LI3	6-14	4-10	127	1.8	4	319	12	34	15	12.5	45.5	71	35	30	13	8431 0616 07
LTC28 R18-10-LI3	10-18	7-13	386	1.8	4	421	10	34	15	12.5	36.7	59.2	35	22	10	8431 0616 02
LTC38 R28-12-LI3	14-28	10-20	470	1.8	4	493	12	34	15	12.5	45.5	71	35	30	13	8431 0616 09
LTC38 R34-21-LI3	16-34	12-25	390	3.7	8.2	578	21	46	20	16	74.5	44	64	40	20	8431 0616 10
LTC48 R80-21-LI3	50-80	37-59	250	4	8.9	578	21	46	20	16	74.5	84	64	40	20	8431 0616 12
LTC48 R135-22-LI3	105-135	77-99	90	4.6	10.2	651	22	46	33	14	77.5	84	64	40	20	8431 0616 15

OFFSET CROWFOOT TOOLS

Dimensions

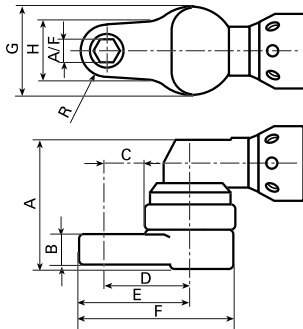

LTC

Model	Torque		Speed r/min	Weight		Length mm	A/F mm	A mm	B mm	C mm	D mm	E mm	F mm	G mm	H mm	R mm	Ordering No.
	Nm	ft lb		kg	lb												
LTC009 R07-10-LO3	3-7	2.2-5	250	1.6	3.6	304	10	59.5	10	14.55	32.8	42.8	61.1	36.5	22	10	8431 0614 94
LTC29-2R19-10-LO3	10-19	7.3-14	640	2	4.4	384	10	60.3	15	14.55	32.8	42.8	61.1	36.5	22	10	8431 0615 02
LTC29-2R21-13-LO5	11-21	8-15	500	2	4.4	457	13	58.5	10	71.6	93.6	108.1	130.1	44	31	14.5	8431 0615 04
LTC39-2R28-12-LO5	17-28	13-21	560	2.5	5.6	488	12	69.5	15	62	84	97	119	44	30	13	8431 0615 08
LTC39-2R40-14-LO3	22-40	16-29	460	2.4	5.3	452	14	77.8	18	24.8	46.8	61.3	83.3	44	31	14.5	8431 0615 11
LTC39-2R60-16-LO3	34-60	25-44	305	3	6.7	541	16	91	24	27	51	66	91.5	48	30	15	8431 0615 14
LTC48 R80-17-LO3	56-80	41-59	215	4	8.9	641	17	69.5	27	30.3	55.8	72.3	97.8	48	33	16.5	8431 0615 17
LTC48 R96-18-LO3	56-96	41-71	210	4.7	10.4	651	18	99	32	32	63.2	82.2	113.5	62.5	38	19	8431 0615 21
Extra heavy duty attachments																	
LTC38 R33-13-A-O-3	16-33	11.8-24	430	2.6	5.8	487	13	60	19	32.8	52.8	68.8	88.8	40	34	16	8431 0611 01
LTC48 R56-17-A-O-3	24-56	18-41	400	3.9	8.7	619	17	66	19	45.1	67.6	87.2	109.7	45	39.2	19.5	8431 0611 06
LTC38 R40-17-A-O-3	23-40	17-29	360	3	6.7	519	17	66	19	45.1	67.6	87.2	109.7	45	39.2	19.5	8431 0611 08
LTC48 R120-19-A-O-3	48-120	36-89	180	4.3	9.6	656	19	87	25	42.3	67.6	87.4	112.7	54	39.5	19.75	8431 0611 15

Tube Nut

Angle Nutrunners

IN-LINE TUBE NUT TOOLS

Dimensions

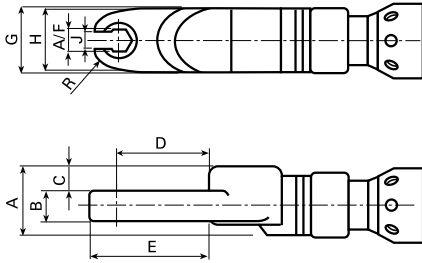

LTO

Model	Torque		Speed r/min	Weight		Length mm	A/F mm	A mm	B mm	C mm	D mm	E mm	G mm	H mm	J mm	R mm	Ordering No.
	Nm	ft lb		kg	lb												
LTO28 R06-8-LI3	2.1-6	1.5-4	833	1.8	4	369	8	32	10	13	27.3	25.4	33.5	31	7	9.8	8431 0617 02
LTO28 R12-8-LI3	6-12	4-8	420	2	4.4	388	8	32	10	13	27.3	25.4	33.5	31	7	9.8	8431 0617 03
LTO28 R12-10-LI3	6-12	4-8	420	2	4.4	396	10	32	10	13	27.3	25.4	33.5	31	7	9.8	8431 0612 44
LTO28 R15-10-LI3	6-15	4-11	400	2	4.4	397	10	32	12	11	27.9	26.1	33.5	32	8	10.3	8431 0612 46
LTO28 R17-13-LI3	8-17	6-13	350	1.9	4.2	415	13	34	11	14.5	36.3	32.3	35	38	8.5	12.4	8431 0612 48
LTO28 R19-10-LI3	8-19	6-14	350	1.9	4.2	402	10	34	14	13	31.9	29.7	35	38	8	11.2	8431 0617 07
LTO38 R26-13-LI3	14-35	10-25	220	3	6.7	536	13	46	11	20.8	52	47.3	45	55	12.5	17.2	8431 0612 50
LTO38 R26-17-LI3	15-43	11-31	200	3.2	7.1	547	17	46	12	20	60.3	38.8	45	59	16	20.1	8431 0612 54
LTO38 R28-12-LI3	10-28	7-20	320	2.9	6.4	514	12	43	11	17.5	43.7	29.3	40	50	10.4	15	8431 0617 08
LTO38 R35-12-LI3	14-35	10-25	220	2.9	6.4	519	12	43	11	17.5	43.7	29.3	40	50	10.4	15	8431 0617 09
LTO38 R43-14-LI3	14-43	10-31	220	3.2	7.1	522	14	46	18	17	41	38.5	45	50	12	15	8431 0617 10

OFFSET TUBE NUT TOOLS

Dimensions

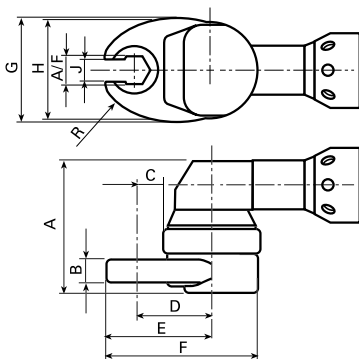

LTO

Model	Torque		Speed r/min	Weight		Length mm	A/F mm	A mm	B mm	C mm	D mm	E mm	F mm	G mm	J mm	R mm	Ordering No.
	Nm	ft lb		kg	lb												
LTO28 R12-12-LO5	6-12	4.4-9	470	2	4.4	402	12	66.5	11	51	73	84.9	106.9	44	8	11.9	8431 0618 05
LTO38 R28-13-LO5	11-28	8.0-20	250	2.3	5.1	506	13	71	18	53.3	75.3	87.7	109.7	44	10.4	12.4	8431 0618 12

Shut-off

Angle Nutrunners

HOLD AND DRIVE

Hold and drive bolts are being used increasingly by, for example, truck manufacturers on the frame assembly line, making what used to be a two-man operation, a one-man task. The distinguishing feature of a hold and drive bolt is that one part is held and the other is tightened from the same side.

LTV HAD

- Especially suitable for shock absorber assembly.
- Special tools based on the standard LTV series are available for use on hold and drive bolts.
- HAD sockets are available in three different lengths.
- Special sockets available upon request.
- Also suitable for break-away bolts, Hi Lok/Hi Shear.



LTV48 R200 HAD

NOTE: To reduce the reaction force in the holder, the use of a reaction bar is recommended.

Model	Bolt size mm	Torque range soft joint ^a		Free speed r/min	Weight		Length mm	Angle head height mm	Angle head center to side mm	Air con- sumption at free speed		Rec. hose size mm	Air inlet thread in	Ordering No.
		Nm	ft lb		kg	lb				l/s	cfm			
LTV38 R40 LT HAD ^b	M8-10	15-40	11-30	210	3.0	6.5	530	75	26	10	16	10	1/4	8431 0609 52
LTV38 R42 HAD	M8	20-42	15-31	430	2.2	4.8	453	62	18.5	10	16	10	1/4	8431 0603 75
LTV38 R50 HAD	M10	25-50	18-36	360	2.2	4.8	453	62	18.5	10	16	10	1/4	8431 0603 82
LTV38 R85 HAD	M10-12	40-85	30-67	210	3.0	6.5	530	75	26	10	16	10	1/4	8431 0609 58
LTV48 R120 HAD	M12-14	70-120	52-89	220	3.3	7.3	590	75	26	28	59	12.5	1/2	8431 0610 26
LTV48 R150 HAD	M14	70-150	52-111	180	3.3	7.3	590	75	26	28	59	12.5	1/2	8431 0610 30
LTV48 R200 HAD	M14	115-200	85-150	100	3.3	7.3	610	75	28	28	59	12.5	1/2	8431 0610 32
LTV69 R370 HAD	M18	190-370	140-273	480	7.6	16.6	634	104	33	20	42	12.5	1/2	8431 0831 65

^a At min 5 bar.

^b For low torque applications.

NOTE: For sockets and holders see accessory pages.

Other types of Hold and Drive equipped tools are available on special request.

Non Shut-off

Angle Nutrunners

STALL TYPE

- Low inertia design gives accurate torque independent of joint stiffness – in other words, low mean shift.
- Easy torque setting by adjusting the inlet air pressure.
- Reliable, well-proven design.
- Good accessibility due to small dimensioned angle head.



Model	Bolt size mm	Square drive in	Torque range soft joint				Free speed r/min	Weight		Length mm	Angle head height mm	Angle head center to side mm	Air consumption at free speed		Rec. hose size mm	Air inlet thread in	Ordering No.
			at 6.3 bar		at 3 bar			kg	lb				l/s	cfm			
Reversible																	
LMV28 R11-10	M6	3/8	11	8	5	4	1200	1.1	2.4	264	28	11	10	21	10	1/4	8431 0591 07
LMV28 R14-10	M6	3/8	14	10	7	5	1000	1.1	2.4	264	29.5	13.5	10	21	10	1/4	8431 0591 09
Non reversible																	
LMV28 N16-10	M6	3/8	16	12	8	6	1000	1.0	2.2	239	29.5	13.5	11	23	10	1/4	8431 0590 17

RATCHET WRENCHES

- Unique accessibility, the ratchet wrench is a superior tool for limited space applications.
- To loosen, turn the tool upside down.



Model	Bolt size mm	Square drive in	Torque range soft joint				Free speed r/min	Weight		Length mm	Angle head height mm	Angle head center to side mm	Air consumption at free speed		Rec. hose size mm	Air inlet thread in	Ordering No.
			at 6.3 bar		at 3 bar			kg	lb				l/s	cfm			
LBR33 S26/114-13	M8	13 ^a	22	16	11	8	185	1.4	3.1	290	15	13	9.5	20	10	1/4	8431 0345 71
LBR33 S26/118-16	M8-10	16 ^a	30	22	15	11	135	1.4	3.1	300	15	18	9.5	20	10	1/4	8431 0346 70
LBR33 S26/118-17	M8-10	17 ^a	30	22	15	11	135	1.4	3.1	300	15	18	9.5	20	10	1/4	8431 0346 62

^a Female hex drive.

WORM-DRIVE NUTRUNNERS

- Teasing throttle characteristics give significantly reduced free speed.
- Suitable for:
 - Nutrunning
 - Light reaming
 - Tapping
 - Tube-rolling
- Can also be incorporated in rigs as air motors for intermittent operation.



Model	Bolt size mm	Square drive in	Torque range soft joint				Free speed r/min	Weight		Length mm	Angle head height mm	Angle head center to side mm	Air consumption at free speed		Rec. hose size mm	Air inlet thread in	Ordering No.
			at 6.3 bar		at 3 bar			kg	lb				l/s	cfm			
LMK33 S001	M10-12	7/16 ^a	55	41	27	20	130	2.2	4.9	385	39	41	9.5	20	10	1/4	8431 0343 08
LMK33 S002	M10-12	7/16 ^a	32	24	16	12	235	1.9	4.2	291	39	41	9.5	20	10	1/4	8431 0343 16
LMK33 S005	M10	7/16 ^a	29	21	14	10	480	1.7	3.7	263	39	41	9.5	20	10	1/4	8431 0343 24

^a Female hex drive.

Accessories Included

FOR LTV MODELS

Clutch adjustment key

FOR LBR, LMV AND LMK MODELS

Socket adapter, 3/8" square drive LMK22,
1/2" square drive LMK33

Optional Accessories

EXTENSIONS FOR LTV

Suitable for tool	Length of extension –"L"		Ordering No.
	mm	in	
LTV28	75	3	4210 3491 93
LTV28	150	6	4210 3491 95
LTV38 (not R70/R85)	75	3	4210 4301 80
LTV38 (not R70/R85)	150	6	4210 4302 80
LTV38 R70/R85/LTV48	75	3	4210 4303 80
LTV38 R70/R85/LTV48	150	6	4210 4304 80
LTV39-2 R48-10	75	3	4210 4472 81
LTV39-2 R48-10	150	6	4210 4472 83
LTV39-2 R48/56/70-13	75	3	4210 4472 80
LTV39-2 R48/56/70-13	150	6	4210 4473 80
LTV39-2 R56-10	75	3	4210 4472 82
LTV39-2 R56-10	150	6	4210 4472 84
LTV39-2 R85	75	3	4210 4474 80
LTV39-2 R85	150	6	4210 4475 80

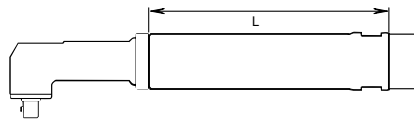

Reaction bar kit



Protective cover (a)



Protective cover (b)

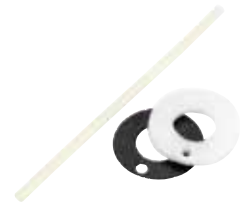

Signal connection kit (RE)

FOR LTV AND LTC MODELS

Model	Exhaust hose	Suspension yoke		Protective cover (see picture)	Reaction bar kit	Signal connection kit (-RE)
		Fixed	Swivelling			
LTV28 R07	4210 2053 00	4210 1631 82	4210 3931 80	4210 3990 00 ^a		4210 4019 90
LTV28, all models except R07	4210 2053 00	4210 1631 82	4210 3931 80	4210 3990 00 ^a		4210 4018 90
LTV29-2/39-2	4210 2053 00	4210 1631 82	4210 4408 80			4210 4017 90
LTV29-2/39-2 R12/R16				4220 2744 05 ^b		
LTV29-2/39-2 R24/R30				4220 2744 03 ^b		
LTV38 R42/R50/R57 LTC38, LTV38 FS	4210 2053 00	4210 1631 82	4210 3931 81	4210 3992 90 ^a (not LTC)		4210 4017 90
LTV38 R70	4210 2053 00	4210 1631 82	4210 3931 81	4210 4003 90 ^a		4210 4017 90
LTV38 R85, LTV38 HAD	4210 2053 00	4210 1631 82	4210 3931 81	4210 4004 90 ^a	4210 4020 80	4210 4017 90
LTV39-2 R48-10/R50-10				4220 2744 02 ^b		
LTV39-2 R48-13/R50-13/R70				4220 2744 04 ^b		
LTV48 R65	4210 4011 00		4210 4021 80	4210 4058 90 ^a	4210 4020 80	4210 4057 90
LTV48 R120/R150/R200, LTC48, LTV48 FS, LTV48 HAD	4210 4011 00		4210 4021 80	4210 4059 90 ^a	4210 4020 80	4210 4057 90
LTV69 N/R180	4210 4011 00		4210 3088 87	4210 4059 90 ^a	4220 1128 80	
LTV69 N/R370	4210 4011 00		4210 3088 87		4220 1201 80	
LTV69 N/R600	4210 4011 00		4210 3088 87		4220 1746 80	

Optional Accessories for Flush socket tools

INTEGRATED SOCKETS

Model	Hexagon socket size AF mm / in	Socket extension mm	Ordering No.
LTV29-2 R24/R30 FS and ETV ST61-30-FS	8	1.5	4220 4188 88
	10	1.5	4220 4188 90
	12	1.5	4220 4188 92
	13	1.5	4220 4188 93
	5/16"	1.5	4220 4188 98
	1/4"	1.5	4220 4188 96
LTV39-2 R37/R48/R56 FS and ETV ST61-40-FS, ETV ST61-50-FS	10	2.5	4220 3987 90
	12	2.5	4220 3987 92
	13	2.5	4220 3987 93
	14	2.5	4220 3987 94
	15	2.5	4220 3987 95
	16	2.5	4220 3987 96
	17	2.5	4220 3987 97
	18	2.5	4220 3987 98
	9/16"	2.5	4220 3987 99
	13	7	4220 4012 93
	13	15	4220 4013 93
	14	15	4220 4013 94
	LTV39-2 R70 FS and ETV ST61-70-FS	16	0.5
15		16.5	4220 1621 00
15		1.5	4220 1621 01
18		6.5	4220 1621 02
16		11.5	4220 1621 03
10		3.5	4220 1621 04
20		8.5	4220 1621 05
17.5		6.5	4220 1621 06
19		8.5	4220 1621 07
16		16.5	4220 1621 08
18		10.5	4220 1621 09
16		14.5	4220 1621 10
19		10	4220 1621 11
17		11.5	4220 1621 12
13		3.5	4210 2749 01
15		3.5	4210 2749 02
12		3.5	4210 2749 03
14		3.5	4210 2749 04
9/16"		3.5	4210 2749 05
7/16"		3.5	4210 2749 06
LTV39-2 R85/R120 FS, LTV48 R150/R200 FS, and ETV DS72-160FS/200FS , ETV ST61 100/150/180/200 FS	24	12.5	4220 1595 01
	18	4.5	4220 1595 02
	25.4	13.5	4220 1595 03
	18	14.5	4220 1595 04
	21	13.5	4220 1595 05
	21	24	4220 1595 06
	14	5.5	4220 1595 07
	14.3	9	4220 1595 08
	17.5	7.5	4220 1595 09
	18	2	4210 3534 68
	18	8.5	4210 3534 18
	19	9.5	4210 3534 19
	21	10.5	4210 3534 21
	22	10.5	4210 3534 22
	24	10.5	4210 3534 24
	27	13.8	4210 3534 27

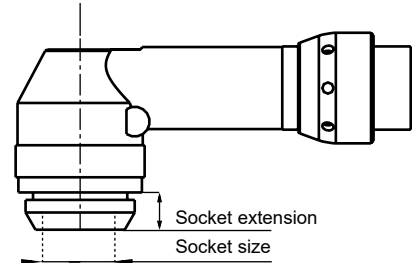

Optional Accessories for Crowfoot tools

HEX SOCKETS

Width across flats		Ordering No.
mm	in	
For LTC38 R33/N41-13-A-O-3^a		
	7/16	4210 2625 03
12		4210 2625 04
	1/2	4210 2625 01
13		4210 2625 00
14		4210 2625 02
15		4210 2625 06
For LTC38 R40/N48-17-A-O-3^b, LTC48 R56-17-A-O-3^b		
13		4210 2626 06
14		4210 2626 04
15		4210 2626 03
	1/2	4210 2626 05
	5/8	4210 2626 02
16		4210 2626 00
17		4210 2626 01
18		4210 2626 10
19		4210 2626 08
For LTC48 R96/R120-19-A-O-3^c		
13		4210 2624 06
14		4210 2624 05
15		4210 2624 04
16		4210 2624 03
17		4210 2624 02
18		4210 2624 01
19	3/4	4210 2624 00

Model	H mm	B mm	C mm
LTC38 R33-13-A-O-3	19	32	16
LTC38 R40-17-A-O-3	19	39	20
LTC48 R56-17-A-O-3	19	39	20
LTC48 R96-19-A-O-3	25	39	20
LTC48 R120-19-A-O-3	25	39	20
LTC38 N41-13-A-O-3	19	32	16

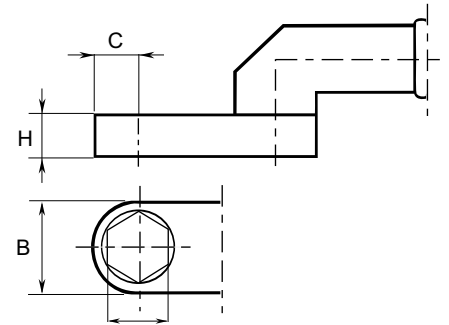

^a 13 mm socket mounted on tool.

^b 17 mm socket mounted on tool.

^c 19 mm socket mounted on tool.

Optional Accessories for Open End Type

SOCKETS

A Socket size mm	B Open end mm	Ordering No.
LTO28 R12-10-L-I-3		
5/16"	7	4210 4288 54
8 mm	7	4210 4288 55
3/8"	7	4210 4288 53
9 mm	7	4210 4288 52
10 mm	7	4210 4288 51
LTO28 R15-10-L-I-3		
8 mm	8	4210 4289 56
9 mm	8	4210 4289 55
3/8"	8	4210 4289 54
10 mm	8	4210 4289 51
11 mm	8	4210 4289 57
7/16"	8	4210 4289 58
12 mm	8	4210 4289 53
LTO28 R17-13-L-I-3		
3/8"	8.5	4210 4290 52
10 mm	8.5	4210 4290 53
11 mm	8.5	4210 4290 59
7/16"	8.5	4210 4290 54
12 mm	8.5	4210 4290 57
1/2"	8.5	4210 4290 55
13 mm	8.5	4210 4290 51
14 mm	8.5	4210 4290 58
9/16"	8.5	4210 4290 56

A Socket size mm	B Open end mm	Ordering No.
LTO38 R26-13-L-I-3		
11 mm	12.5	4210 4291 63
13 mm	12.5	4210 4291 51
14 mm	12.5	4210 4291 58
9/16"	12.5	4210 4291 53
15 mm	12.5	4210 4291 55
5/8"	12.5	4210 4291 54
16 mm	12.5	4210 4291 52
17 mm	12.5	4210 4291 60
11/16"	12.5	4210 4291 56
18 mm	12.5	4210 4291 61
19 mm	12.5	4210 4291 62
3/4"	12.5	4210 4291 57
LTO38 R26-17-L-I-3		
14 mm	14	4210 4292 55
5/8"	14.6	4210 4292 54
17 mm	16	4210 4292 51
18 mm	16	4210 4292 53
19 mm	16	4210 4292 57
3/4"	16	4210 4292 52
20 mm	16	4210 4292 61
13/16"	16	4210 4292 63
21 mm	16	4210 4292 62
22 mm	16	4210 4292 56
7/8"	16	4210 4292 58
15/16"	16	4210 4292 60
24 mm	17.2	4210 4292 59

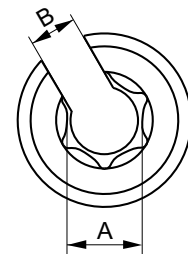

Optional Accessories for Stall type

FEMALE HEX SOCKETS

Dimensions in	Ordering No. LBR33 S26/114	Ordering No. LBR33 S26/118	Dimensions in	Ordering No. LBR33 S26/114	Ordering No. LBR33 S26/118
1/4	4210 0360 05	–	10	4210 0414 10	–
5/16	4210 0360 02	–	12	4210 0414 12	4210 0418 12
3/8	4210 0360 03	4210 0389 02	13	4210 0414 13	4210 0418 13
7/16	4210 0360 04	4210 0389 03	14	4210 0414 14	4210 0418 14
1/2	4210 0360 01	4210 0389 04	15	4210 0414 15	4210 0418 15
9/16	–	4210 0389 06	16	–	4210 0418 16
5/8	–	4210 0389 01	17	–	4210 0418 17
3/4	–	4210 0389 05	18	–	4210 0418 18
			19	–	4210 0389 05

NOTE: That 1/2" female hex sockets must be used together with socket adapters.

SOCKET ADAPTERS

Dimensions	Ordering No. LBR33 S26/114	Ordering No. LBR33 S26/118
1/2" hex 3/8" square drive	4090 0163 00	4090 0163 00
1/2" hex 1/2" square drive	4090 0164 00	4090 0164 00

Optional Accessories for Hold and Drive tools

NUT SOCKET, SCREW HOLDER AND BIT HOLDER FOR LTV38 R42-HAD/LTV38 R50-HAD AND ETV ST61-28/50 HAD

Nut socket (Fig. 1)

Width across flats W mm	Socket Ø D mm	Ordering No. A	Ordering No. B	Ordering No. C
10	22	4220 1769 16	4220 1769 31	4220 1769 51
11	22	4220 1769 15	4220 1769 32	4220 1769 52
12	22	4220 1769 13	4220 1769 33	4220 1769 53
13	22	4220 1769 09	4220 1769 12	4220 1769 54
14	22	4220 1769 05	4220 1769 35	4220 1769 08
15	22	4220 1769 14	4220 1769 36	4220 1769 56
16	25	4220 1888 71	4220 1888 81	4220 1888 91
17	25	4220 1888 72	4220 1888 82	4220 1888 92
18	26	4220 1888 73	4220 1888 83	4220 1888 93
19	27	4220 1888 74	4220 1888 84	4220 1888 94
20	31	4220 1888 75	4220 1888 85	4220 1888 95
21	31	4220 1888 76	4220 1888 86	4220 1888 96

Measurements in mm

Figure 1

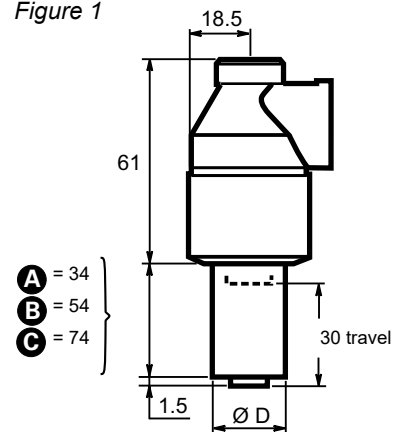

Screw holder

Dimension X x Y mm	Suitable socket size mm	Ordering No. A	Ordering No. B	Ordering No. C
6.6 x 5	10-21	4220 1770 19	–	–
7 x 5	10-21	–	4220 1770 17	–
5.1 x 8.2	10-21	4220 1770 01	–	4220 1770 16
8 x 6	10-21	4220 1770 02	–	–

Two flats

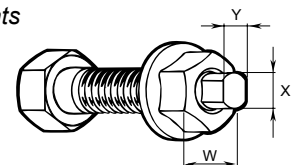

Bit holder

Bit holder 1/4"				
A	B	C	Width N, mm	Bits
4220 1959 01	4220 1959 04	4220 1959 03	10-21	1/4"

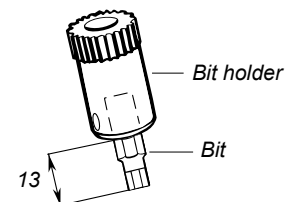

Optional Accessories for Hold and Drive tools

NUT SOCKET, SCREW HOLDER AND BIT HOLDER FOR LTV48 R100-HAD AND ETV ST61/81-100-HAD

Nut socket (Fig. 2)

Width across flats W mm	Socket Ø D mm	Ordering No.		
		A	B	C
13	21	4220 4477 13	4220 4477 33	4220 4477 53
14	22	4220 4477 14	4220 4477 34	4220 4477 54
15	23	4220 4477 15	4220 4477 35	4220 4477 55
16	24	4220 4477 16	4220 4477 36	4220 4477 56
17	27	4220 4477 17	4220 4477 37	4220 4477 57
18	27	4220 4477 18	4220 4477 38	4220 4477 58
19	29	4220 4477 19	4220 4477 39	4220 4477 59
21	30	4220 4477 21	4220 4477 41	4220 4477 61
22	32	4220 4477 22	4220 4477 42	4220 4477 62
24	34	4220 4477 24	4220 4477 44	4220 4477 64

Measurements in mm

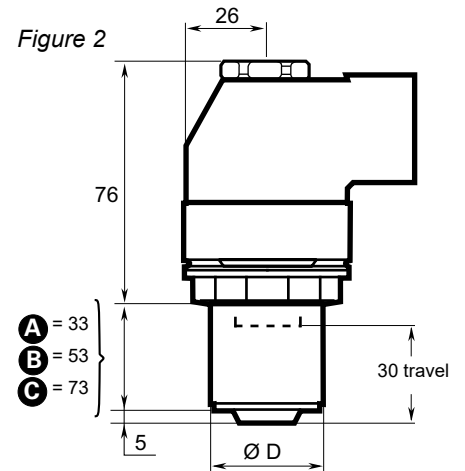

Screw holder – Two flats

Dimension X x Y mm	Suitable socket size mm	Ordering No.		
		A 33 mm	B 53 mm	C 73 mm
7x5	13-24	4220 4524 05	4220 4524 15	4220 4524 25
8x6	13-24	4220 4524 06	4220 4524 16	4220 4524 26
8x6.3	13-24	4220 4524 07	4220 4524 17	4220 4524 27
9.55x7.6	14-24	4220 4524 08	4220 4524 18	4220 4524 28
11.20x8.9	16-24	4220 4524 09	4220 4524 19	4220 4524 29
13x9.8	16-24	4220 4524 10	4220 4524 20	4220 4524 30

Two flats

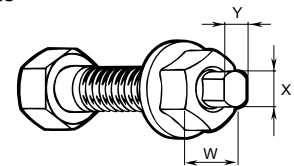

Screw holder – Male hexagon

Dimension N mm	Suitable socket size mm	Ordering No.		
		A 33 mm	B 53 mm	C 73 mm
5	13-24	4220 4478 15	4220 4478 25	4220 4478 45
6	13-24	4220 4478 16	4220 4478 26	4220 4478 46
7	13-24	4220 4478 07	4220 4478 27	4220 4478 47
8	13-24	4220 4478 08	4220 4478 28	4220 4478 48
9	14-24	4220 4478 09	4220 4478 29	4220 4478 49
10	16-24	4220 4478 10	4220 4478 30	4220 4478 50
11	16-24	4220 4478 11	4220 4478 31	4220 4478 51

Male hexagon

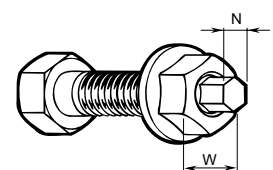

Bit holder – Female hexagon

Suitable socket size mm	Ordering No.		
	A 33 mm	B 53 mm	C 73 mm
13-24	4220 4524 60	4220 4524 61	4220 4524 62

Female hexagon

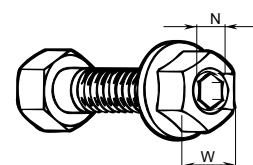

Optional Accessories for Hold and Drive tools

NUT SOCKET, SCREW HOLDER AND BIT HOLDER FOR LTV38 R40 LT/R 85 HAD, LTV48 HAD AND ETV ST61/81-100-HAD-HD/120/150/180/200 HAD

Nut socket (Fig. 3)

Width across flats W mm	Socket Ø D mm	Ordering No.		
		A	B	C
13	30	4210 3513 13	4210 3513 33	4210 3513 53
14	30	4210 3513 14	4210 3513 34	4210 3513 54
15	30	4210 3513 15	4210 3513 35	4210 3513 55
16	30	4210 3513 16	4210 3513 36	4210 3513 56
17	30	4210 3513 17	4210 3513 37	4210 3513 57
18	31	4210 3513 18	4210 3513 38	4210 3513 58
19	32	4210 3513 19	4210 3513 39	4210 3513 59
21	35	4210 3513 21	4210 3513 41	4210 3513 61
22	35	4210 3513 22	4210 3513 42	4210 3513 62
24	35	4210 3513 24	4210 3513 44	4210 3513 64

Measurements in mm

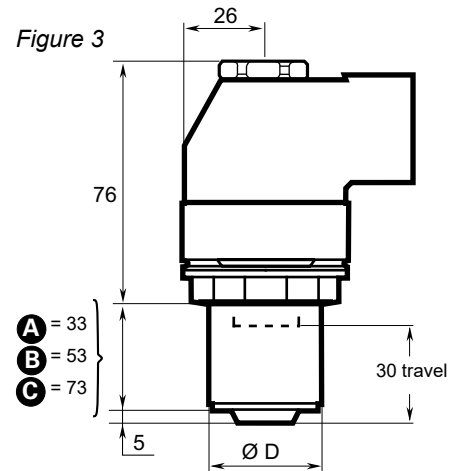

Screw holder – Two flats

Dimension X x Y mm	Suitable socket size mm	Ordering No.		
		A	B	C
8 x 6.3	15-24	4210 2694 17	4210 2694 18	4210 2694 19
8 x 6	15-24	4210 2694 05	4210 2694 10	4210 2694 15
9.55 x 7.6	18-24	4210 2694 01	4210 2694 06	4210 2694 11
11.20 x 8.9	19-24	4210 2694 02	4210 2694 07	4210 2694 12
13 x 9.8	19-24	4210 2694 03	4210 2694 08	4210 2694 13
13.20 x 10.5	19-24	4210 2694 04	4210 2694 09	4210 2694 14

Two flats

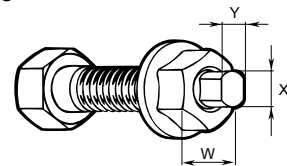

Screw holder – Male hexagon

Dimension N mm	Suitable socket size mm	Ordering No.		
		A	B	C
7	14-24	4210 2825 41	4210 2825 42	4210 2825 43
8	14-24	4210 2825 01	4210 2825 05	4210 2825 09
9	15-24	4210 2825 02	4210 2825 06	4210 2825 10
10	18-24	4210 2825 03	4210 2825 07	4210 2825 11
11	19-24	4210 2825 04	4210 2825 08	4210 2825 12
12	19-24	4210 2825 13	4210 2825 14	4210 2825 15

Male hexagon

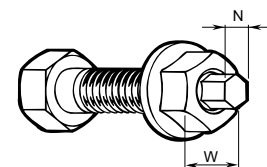

Bit holder – Female hexagon

Bit holder 5/16"			5/16" Bits	
A	B	C	Width N, mm	Ordering No.
4210 2991 91	4210 2991 92	4210 2991 93	5	4023 1215 00
			6	4023 1216 00
			7	4023 1219 00
			8	4023 1217 00
			10	4023 1218 00

Female hexagon

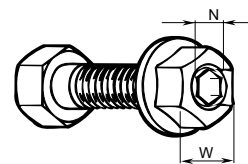

Optional Accessories for Hold and Drive tools

NUT SOCKET, SCREW HOLDER AND BIT HOLDER FOR LTV69 R370-HAD AND ETV ST101-370-HAD

Nut socket (Fig. 4)

Width across flats W mm	Socket Ø D mm	Ordering No.		
		A	B	C
18	41	4220 1778 04	4220 1778 14	4220 1778 24
19	41	4220 1778 05	4220 1778 15	4220 1778 25
20	41	4220 1778 06	4220 1778 16	4220 1778 26
21	41	4220 1778 07	4220 1778 17	4220 1778 27
22	41	4220 1778 08	4220 1778 18	4220 1778 28
23	41	4220 1778 09	4220 1778 19	4220 1778 29
24	41	4220 1778 01	4220 1778 11	4220 1778 21
25	41	4220 1778 02	4220 1778 12	4220 1778 22
25.4=1"	41	4220 1778 10	4220 1778 20	4220 1778 30
26	41	4220 1778 03	4220 1778 13	4220 1778 23
27	46	-	4220 2139 84	4220 2139 94
28	46	-	4220 2139 83	4220 2139 93
29	46	-	4220 2139 82	4220 2139 92
30	46	-	4220 2139 81	4220 2139 91
31	54	-	4220 2297 81	4220 2297 91
32	54	-	4220 2297 82	4220 2297 92
33	54	-	4220 2297 83	4220 2297 93
34	54	-	4220 2297 84	4220 2297 94
35	54	-	4220 2297 85	4220 2297 95
36	54	-	4220 2297 86	4220 2297 96

Measurements in mm

Figure 4

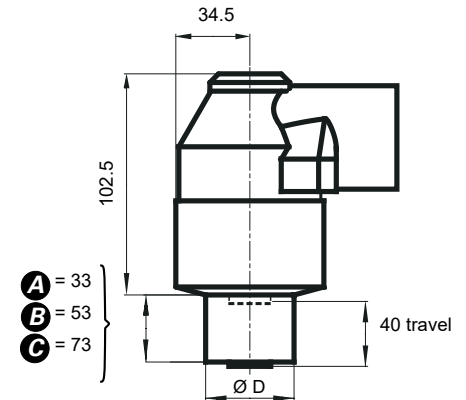

Screw holder – Two flats for LTV69 R370-HAD

Dimension X x Y N mm	Suitable socket size mm	Ordering No.		
		A	B	C
13 x 9.8	18-36	4220 1777 80	4220 1777 83	4220 1777 85
13.20 x 10.5	18-36	4220 1777 81	4220 1777 84	4220 1777 86

Screw holder – Male hexagon for LTV69 R370-HAD

Dimension N mm	Suitable socket size mm	Ordering No.		
		A	B	C
10	18-36	4220 1777 52	4220 1777 54	4220 1777 72
11	18-36	4220 1777 51	4220 1777 50	4220 1777 73
12	20-36	4220 1777 53	4220 1777 55	4220 1777 74
14	20-36	4220 1777 57	4220 1777 56	4220 1777 75
16	24-36	4220 1777 58	4220 1777 70	4220 1777 76
18	24-36	4220 1777 59	4220 1777 71	4220 1777 77

Bit holder

Bit holder	Socket size mm	Ordering No.		
		A	B	C
7	14-24	4210 2825 41	4210 2825 42	4210 2825 43
5/16"	18-20	4220 1777 88	4220 1777 89	4220 1777 90
5/16"	21-36	4220 1777 82	4220 1777 85	4220 1777 87

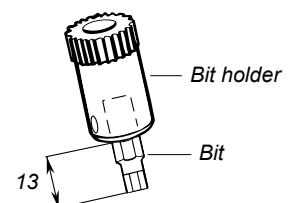

NOTE: 8 mm bit is included in the bit holders.

Productivity Kits

Model	Max air flow	Hose, 5 m	Coupling	Lubrication	Ordering No.
For small nutrunners with 3/8" BSP air inlet					
MIDI Optimizer F/RD EQ08-C10	16 l/s	Cabclair 10 mm	ErgoQIC 08	Yes	8202 0850 07
For small nutrunners with 1/4" BSP air inlet					
MIDI Optimizer F/RD EQ08-C10	16 l/s	Cabclair 10 mm	ErgoQIC 08	Yes	8202 0850 03
MIDI Optimizer F/RD EQ10-R10	16 l/s	Rubair 10 mm	ErgoQIC 10	Yes	8202 0850 16
For nutrunners with 3/8" BSP air inlet					
MIDI Optimizer F/RD EQ10-C13	23 l/s	Cabclair 13 mm	ErgoQIC 10	Yes	8202 0850 02
For nutrunners with 1/4" BSP air inlet					
MIDI Optimizer F/RD EQ10-C13-1/4	23 l/s	Cabclair 13 mm	ErgoQIC 10	Yes	8202 0850 11
For nutrunners with 3/8" BSP air inlet					
MIDI Optimizer F/RD EQ10-T13	35 l/s	Turbo 13 mm	ErgoQIC 10	Yes	8202 0850 17
For nutrunners with 1/2" BSP air inlet					
MIDI Optimizer F/R EQ10-T13	35 l/s	Turbo 13 mm	ErgoQIC 10	No	8202 0850 04
MIDI Optimizer F/RD EQ10-T13	35 l/s	Turbo 13 mm	ErgoQIC 10	Yes	8202 0850 13



Service Kits

The spare parts included in the service kits cover a normal overhaul of your tool. Always have them available for a fast and economical repair.

Main parts included:

- Vane kit
- Motor bearings
- Gaskets
- O-rings
- Circlips
- Pins etc.

Model	Service kit
LTV28	4081 0102 90
LTV29-2	4081 0299 90
LTV38	4081 0103 90
LTV39-2	4081 0298 90
LTV48	4081 0236 90
LTV69	4081 0397 90

Introduction – Straight Nutrunners

Fast, flexible and user-friendly

The LTD system offers a flexible, low-cost solution to many advanced tightening requirements. With fixtured tools the operator influence is minimized and very high torque accuracy is achieved.

ARTICULATING ARMS

Where a fixed support on the workpiece for a reaction bar is not available, a telescopic or articulated arm mounted LTD nutrunner can be an efficient solution.

- **Reaction bar blanks** – For single spindle hand-held applications.
- **Mounting plates** – The LTD straight nutrunners have a splined reaction bar connection which can also be used for fixed assembly of the nutrunner. A number of standard mounting plates are available to order.
- **Floating square drive** – For two or more spindles the units must usually have floating spindles to compensate for run-down variations. Models with floating square drive or telescopic front parts are available.
- **Fixture punches** – For mounting of the nutrunner to locally made base plates a punch for the splines connection is available as optional equipment.
- **Air signal outlets** – All LTD models are equipped with air signal outlets for completed operation.

THE LTD SYSTEM

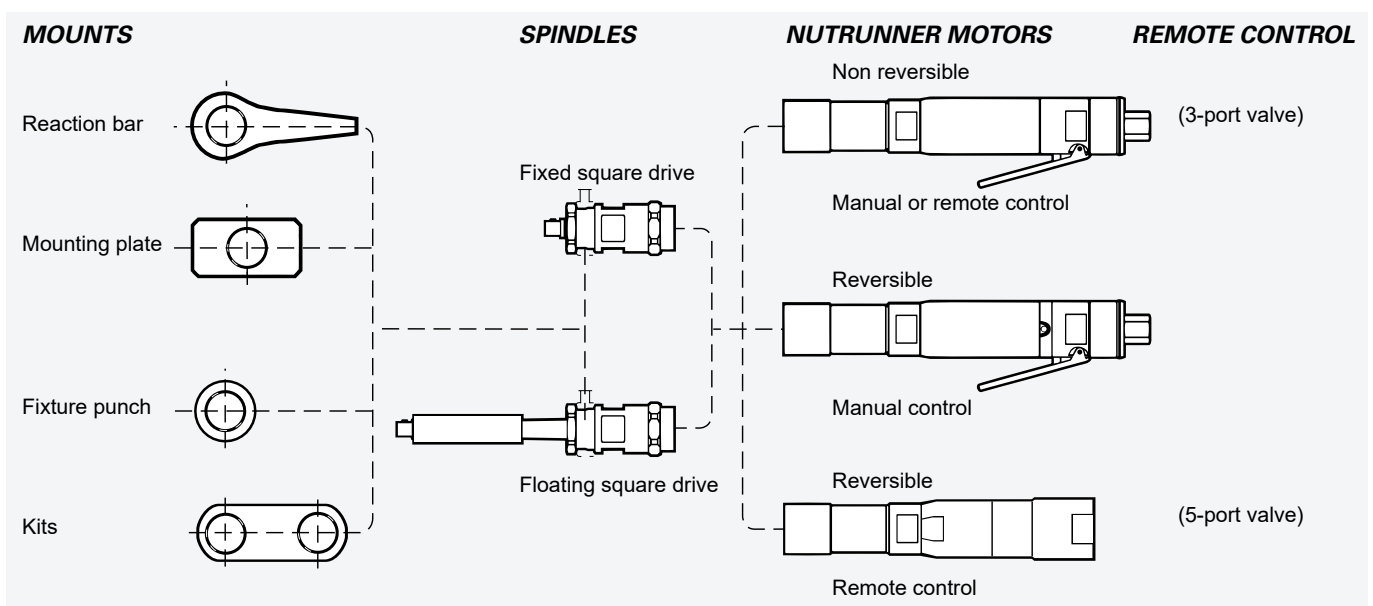

Shut-off

Straight Nutrunners

LTD28, 38 and 48 straight nutrunners are based on the power package and clutch from the LTV angle nutrunners.

LTD nutrunners are based on the unique LTP range of twin motor pistol grip nutrunners. With fast run-down and accurate final tightening they offer high productivity and unmatched torque accuracy as well as joint independence.

- Remote control back head – A remote valve is connected to the back head of the LTD-RR tools allowing a better multiple.
- Accessibility – Slim design allows the building of smooth, simple multiples or paired spindle designs. The absence of a clutch makes these tools shorter.
- Flexibility – The range of LTD tools provides you with the options you need to meet your requirements.
- Reversibility – Reversible LTD tools are available.



Model	Bolt size mm	Square drive in	Torque range soft joint		Free speed r/min	Weight		Length mm	CS distance mm	Air consumption at free speed		Rec. hose size mm	Air inlet thread in	Ordering No.
			Nm	ft lb		kg	lb			l/s	cfm			
Non reversible, lever start														
LTD28 N18-RE	M6	3/8	8-18	6-13	780	1.2	2.6	358	20	9	19	10	1/4	8431 0534 08
LTD28 N22-RE	M6	3/8	10-22	7-16	140	1.2	2.6	358	20	9	19	10	1/4	8431 0534 18
Reversible, lever start														
LTD28 R8-RE	M5-6	3/8	3-8	2-6	1100	1.2	2.6	363	20	8	17	10	1/4	8431 0534 61
LTD28 R16-RE	M6	3/8	7-16	6-12	610	1.3	2.9	383	20	8	17	10	1/4	8431 0534 65
LTD28 R20-RE	M6-8	3/8	10-20	7-15	520	1.3	2.9	383	20	8	17	10	1/4	8431 0534 51
LTD28 R22-RE	M6-8	3/8	10-22	7-16	125	1.3	2.9	383	20	8	17	10	1/4	8431 0534 54
Reversible, remote control back head														
LTD13 R05-RR	M3-5	1/4 ^b	1.5-5	1.1-3.7	850	0.7	1.6	197	16	7	15	8	1/8	8431 0533 05
LTD13 R08-RR	M3-5	1/4 ^b	1.5-8	1.1-6	500	0.8	1.7	197	16	7	15	8	1/8	8431 0533 06
LTD28 R16-RR	M6	3/8	7-16	6-12	610	1.3	2.9	313	20	8	17	10/13	^a	8431 0703 82
LTD28 R20-RR	M6-8	3/8	10-20	7-15	520	1.3	2.9	313	20	8	17	10/13	^a	8431 0703 83
Non reversible, lever start, telescopic front part, travel 25 mm														
LTD28 N18F-RE	M6	3/8	8-18	6-13	780	1.6	3.5	466	20	9	19	10	1/4	8431 0534 27
LTD28 N21F-RE	M6	3/8	10-21	7-15	570	1.6	3.5	466	20	9	19	10	1/4	8431 0534 39
Reversible, lever start, telescopic front part, travel 25 mm														
LTD28 R16F-RE	M6	3/8	7-16	6-12	620	1.7	3.7	491	20	8	17	10	1/4	8431 0534 85
LTD28 R20F-RE	M6-8	3/8	10-20	7-15	570	1.7	3.7	491	20	8	17	10	1/4	8431 0534 37
LTD28 R22F-RE	M6-8	3/8	10-22	7-16	125	1.7	3.7	491	20	8	17	10	1/4	8431 0534 89
Reversible, remote control back head, telescopic front part, travel 25 mm														
LTD28 R8F-RR	M5-6	3/8	3-8	2-6	1100	1.6	3.5	401	20	8	17	10/13	^a	8431 0703 84
LTD28 R16F-RR	M6	3/8	7-16	6-12	620	1.7	3.7	421	20	8	17	10/13	^a	8431 0703 86
LTD28 R20F-RR	M6-8	3/8	10-20	7-15	570	1.7	3.7	421	20	8	17	10/13	^a	8431 0703 88
Non-reversible, lever start														
LTD38 N30-RE	M8	1/2	14-30	10-21	820	2.2	4.8	414	20	16	34	10	1/4	8431 0535 04
LTD38 N55-RE	M10	1/2	27-55	20-40	470	2.2	4.8	487	20	20	42	10	1/4	8431 0535 20
Reversible, lever start														
LTD38 R27-RE	M8	1/2	13-27	10-20	670	2.1	4.6	441	20	16	34	10	1/4	8431 0534 53
LTD38 R32-RE	M8	1/2	18-32	13-24	560	2.1	4.6	441	20	16	34	10	1/4	8431 0534 52
LTD38 R38-RE	M8-10	1/2	19-38	14-28	480	2.1	4.6	441	20	16	34	10	1/4	8431 0535 78
LTD38 R47-RE	M8-10	1/2	22-47	16-35	380	2.3	5.1	513	20	20	42	10	1/4	8431 0535 83
Reversible, remote control back head														
LTD38 R27-RR	M8	1/2	13-27	10-20	670	2.1	4.6	377	21	16	34	10/16	^a	8431 0704 22
LTD38 R32-RR	M8	1/2	18-32	13-24	560	2.1	4.6	377	21	16	34	10/16	^a	8431 0704 24
LTD38 R38-RR	M8-10	1/2	19-38	14-28	480	2.1	4.6	377	21	16	34	10/16	^a	8431 0704 26
LTD38 R47-RR	M8-10	1/2	22-47	16-35	380	2.3	5.1	448	21	16	34	10/16	^a	8431 0704 28

^a Air inlet thread = 2 x 1/4" + 1 x 3/8".

^c Air inlet thread = 2 x 1/2" + 1 x 3/4".

^b 1/4" quick change chuck.

Shut-off

Straight Nutrunners

Model	Bolt size mm	Square drive in	Torque range soft joint		Free speed r/min	Weight		Length mm	CS distance mm	Air consumption at free speed		Rec. hose size mm	Air inlet thread in	Ordering No.
			Nm	ft lb		kg	lb			l/s	cfm			
Non-reversible, lever start, telescopic front part, travel 25 mm														
LTD38 N30F-RE	M8	1/2	14-30	10-21	820	2.3	5.0	521	20	20	42	10	1/4	8431 0535 38
LTD38 N44F-RE	M8-10	1/2	18-44	13-32	580	2.3	5.0	521	20	20	42	10	1/4	8431 0535 31
Reversible, lever start, telescopic front part, travel 25 mm														
LTD38 R27F-RE	M8	1/2	13-27	10-20	670	2.5	5.5	546	20	16	34	10	1/4	8431 0535 65
LTD38 R32F-RE	M8	1/2	18-32	13-24	560	2.5	5.5	546	20	16	34	10	1/4	8431 0535 91
LTD38 R47F-RE	M8-10	1/2	22-47	16-35	380	2.7	5.9	625	23	16	34	10	1/4	8431 0535 99
Reversible, remote control back head, telescopic front part, travel 25 mm														
LTD38 R27F-RR	M8	1/2	13-27	10-20	670	2.5	5.5	482	21	16	34	10/16	^a	8431 0704 30
LTD38 R32F-RR	M8	1/2	18-32	13-24	560	2.5	5.5	482	21	16	34	10/16	^a	8431 0704 32
LTD38 R38F-RR	M8-10	1/2	19-38	14-28	480	2.5	5.5	482	21	16	34	10/16	^a	8431 0704 34
LTD38 R47F-RR	M8-10	1/2	22-47	16-35	380	2.7	5.9	566	23	16	34	10/16	^a	8431 0704 36
Reversible, lever start														
LTD48 R65-RE	M10	1/2	27-65	20-48	400	3.1	6.8	582	30	28	59	12.5	1/2	8431 0637 07
LTD48 R81-RE	M12	1/2	32-81	24-60	320	3.1	6.8	582	30	28	59	12.5	1/2	8431 0637 12
Reversible, remote control back head														
LTD48 R65-RR	M10	1/2	27-65	20-48	400	3.5	7.7	410	28	30	63	12.5/16	^c	8431 0704 46
LTD48 R81-RR	M12	1/2	32-81	24-60	330	3.5	7.7	410	28	30	63	12.5/16	^c	8431 0704 48
Reversible, lever start, telescopic front part, travel 25 mm														
LTD48 R65F-RE	M10	1/2	27-65	20-48	400	3.5	7.7	700	30	28	59	12.5	1/2	8431 0637 17
LTD48 R81F-RE	M12	1/2	32-81	24-60	320	3.5	7.7	700	30	28	59	12.5	1/2	8431 0637 23
Reversible, remote control back head														
LTD48 R65F-RR	M10	1/2	27-65	20-48	400	3.7	8.2	522	28	30	63	12.5/16	^c	8431 0704 50
LTD48 R81F-RR	M12	1/2	32-81	24-60	330	3.7	8.2	522	28	30	63	12.5/16	^c	8431 0704 52

^a Air inlet thread = 2 x 1/4" + 1 x 3/8".

^c Air inlet thread = 2 x 1/2" + 1 x 3/4".

^b 1/4" quick change chuck.

Shut-off

Straight Nutrunners

Model	Bolt size mm	Square drive in	Torque range at 6.3 bar		Min torque at 3 bar		Free speed r/min	Weight		Length mm	CS distance mm	Air consumption at free speed		Air inlet thread in	Spline type	Ordering No.
			Nm	ft lb	Nm	ft lb		kg	lb			l/s	cfm			
Torque control models with fixed square drive																
LTD61 H100-13-RE	M12	1/2	55-100	40-75	45	35	1800	3.0	6.6	223	29	20	42	3/8	3	8431 0808 06
LTD61 H170-13-RE	M14	1/2	95-170	70-125	70	50	1100	3.0	6.6	223	29	20	42	3/8	3	8431 0808 15
LTD61 H230-19-RE	M16	3/4	125-230	90-170	85	60	820	3.0	6.6	223	29	20	42	3/8	3	8431 0808 23
LTD61 H350-20-RE	M18	3/4	190-350	140-255	145	105	520	3.9	8.6	260	31	20	42	3/8	4	8431 0808 27
LTD61 H500-20-RE	M20	3/4	275-500	200-370	220	160	360	3.9	8.6	260	31	20	42	3/8	4	8431 0808 36
LTD61 H700-25-RE	M22	1	360-650	265-480	280	207	280	4.5	9.9	305	34	20	42	3/8	5	8431 0808 43
LTD61 H900-25-RE	M24	1	480-870	350-640	300	220	210	4.5	9.9	282	32	20	42	3/8	5	8431 0808 45

NOTE: Change over torque is around 4% of maximum torque on a given pressure.

Dimensions

TELESCOPIC FRONT PART LTD61

Model	Dimensions						Ordering No.
	N in	D mm	F mm	L mm	M mm	t mm	
LTD61 H100, H170	1/2	34	25	101	127	12	4210 3864 80
LTD61 H230	3/4	41	25	117	148	12	4210 3789 80
LTD61 H350, H500	3/4	50	40	160	201	15	4210 3781 81
LTD61 H700, H900	1	67	50	226	278	15	4210 3788 80

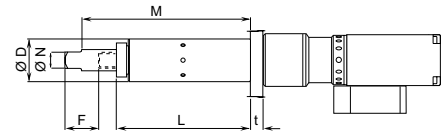

Accessories Included

FOR ALL MODELS

Torque adjustment key

Productivity Kits

Model	Max air flow	Hose, 5 m	Coupling	Lubrication	Ordering No.
For small nutrunners with 3/8" BSP air inlet					
MIDI Optimizer F/RD EQ08-C10	16 l/s	Cablair 10 mm	ErgoQIC 08	Yes	8202 0850 07
For small nutrunners with 1/4" BSP air inlet					
MIDI Optimizer F/RD EQ08-C10	16 l/s	Cablair 10 mm	ErgoQIC 08	Yes	8202 0850 03
MIDI Optimizer F/RD EQ10-R10	16 l/s	Rubair 10 mm	ErgoQIC 10	Yes	8202 0850 16
For nutrunners with 3/8" BSP air inlet					
MIDI Optimizer F/RD EQ10-C13	23 l/s	Cablair 13 mm	ErgoQIC 10	Yes	8202 0850 02
For nutrunners with 1/4" BSP air inlet					
MIDI Optimizer F/RD EQ10-C13-1/4	23 l/s	Cablair 13 mm	ErgoQIC 10	Yes	8202 0850 11
For nutrunners with 3/8" BSP air inlet					
MIDI Optimizer F/RD EQ10-T13	35 l/s	Turbo 13 mm	ErgoQIC 10	Yes	8202 0850 17
For nutrunners with 1/2" BSP air inlet					
MIDI Optimizer F/R EQ10-T13	35 l/s	Turbo 13 mm	ErgoQIC 10	No	8202 0850 04
MIDI Optimizer F/RD EQ10-T13	35 l/s	Turbo 13 mm	ErgoQIC 10	Yes	8202 0850 13



Service Kits



Model	General service kit
LTD61	4081 0397 90

Optional Accessories

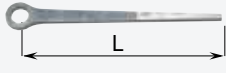
REACTION BAR

	Dimensions mm	LTD38 N55/R47 LTD48 LMD/LTD61 -13, -19				
		LTD28	LTD38	LMD/LTD61 -20	LMD/LTD61 -25	
Bar blank (steel)	L 250 200 500	4210 1798 00	4210 2134 00	4210 2219 82	4210 2183 80	4210 2726 80
Bar blank (aluminum)	400			4210 2219 81		

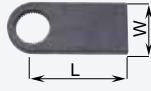
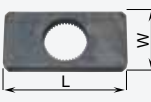
MOUNTING PLATE

	Dimensions mm	LTD38 N55/R47 LTD48 LMD/LTD61 -13, -19				
		LTD28	LTD38	LMD/LTD61 -20	LMD/LTD61 -25	
Side mount 	L x W 90 x 40 120 x 70	4210 1798 01	4210 2134 01		4210 2809 80	4210 2808 80
Center mount 	L x W 70 x 40 100 x 50 125 x 65	4210 1798 02	4210 2134 02	4210 2219 03	4210 2183 01	4210 2726 01
Flange mount 	D 55			4210 2219 10		

VALVE KITS.

INCLUDES: MAIN VALVE, THROTTLE HANDLE VALVE/VALVES, BRACKET, HOSE NIPPLES AND HOSE CLAMPS.
EACH VALVE KIT CAN CONTROL 2 NUTRUNNERS.

Intended for tool type	Valve type	Ordering No.
LTD28/38 RE	3-gate for non reversible	4210 4162 80
LTD28 RR	5-gate for reversible	4210 4163 80
LTD48 RE	3-gate for non reversible	4210 4166 80
LTD38/48 RR	5-gate for reversible	4210 4167 80
LTD61 H100, H170, H230	3-gate for non reversible	4210 4166 80

NOTE: Each valve kit can control two nutrunners

EXHAUST MANIFOLDS.

INCLUDES: BLOCK, SILENCER WITH GASKET AND NIPPLES.

Intended for tool type	Ordering No.
LTD28 RR	4210 4168 80

Introduction – Pistol Grip Nutrunners

An optimum combination of torque, speed and weight

With the range of pistol grip nutrunners from Atlas Copco you get the highest possible torque and speed in relation to the weight of the tool. Fast, accurate and highly operator friendly, the tools are available in reversible versions for maximum flexibility.

FAST AND ACCURATE

In LTP/LMP61 tools the twin motor concept provides extremely fast rundown with good torque accuracy, even on soft joints.

OPERATOR FRIENDLY

Our pistol grip nutrunners are comfortable to operate. The reaction bar eliminates reaction forces and the exhaust through the handle arrangement keeps noise levels low.

Single-handed operation combined with the low weight and perfectly balanced pistol grip design make LMP24/61 and LTP61 nutrunners safe and comfortable to use.

REVERSIBLE FOR MAXIMUM FLEXIBILITY

Being able to loosen fasteners without changing tools saves time and effort and raises productivity.



Non Shut-off

Pistol Grip Nutrunners

The twin motor in the 61 series gives faster production and increased accuracy with a minimum of air consumption. Torque level on LMP models depends on the pressure of the air fed to the tool, higher pressure creates higher torque.

- High torque accuracy.
- Swiveling function makes tool positioning easy on the 61 series.
- Fast rundown motor saves time.
- Extremely good torque output to weight ratio compared to single motor pistol grip nutrunners.
- Available as both reversible and non-reversible models.



Model	Bolt size mm	Square drive in	Max torque at 6.3 bar		Min torque at 3 bar		Free speed r/min	Weight ^a		Length mm	CS distance mm	Air consumption at free speed		Air inlet thread in	Spline type	Ordering No.
			Nm	ft lb	Nm	ft lb		kg	lb			l/s	cfm			
Non-reversible																
LMP24 H005-10	M8	3/8	30	22	14	10	500	1.0	2.2	210	18	11	23	1/4	1	8431 0245 49
LMP24 H003-13	M8	1/2	40	30	14	10	330	1.2	2.6	210	18	11	23	1/4	1	8431 0245 64
LMP24 H002-13	M10	1/2	58	43	27	20	240	1.3	2.9	230	21	11	23	1/4	2	8431 0245 31
LMP61 H100-13	M12	1/2	100	75	60	45	2200	3.0	6.6	223	29	20	42	3/8	3	8431 0803 05
LMP61 H170-13	M14	1/2	170	125	100	75	1400	3.0	6.6	223	29	20	42	3/8	3	8431 0803 12
LMP61 H230-19	M16	3/4	230	170	130	95	1000	3.0	6.6	223	29	20	42	3/8	3	8431 0803 19
LMP61 H350-20	M18	3/4	350	260	200	145	650	3.9	8.6	260	31	20	42	3/8	4	8431 0803 26
LMP61 H500-20	M20	3/4	500	370	300	220	450	3.9	8.6	260	31	20	42	3/8	4	8431 0803 33
LMP61 H700-25	M22	1	700	520	400	295	350	4.5	9.9	305	34	20	42	3/8	5	8431 0803 40
LMP61 H900-25	M24	1	900	665	500	365	260	4.5	9.9	282	34	20	42	3/8	5	8431 0803 47
Reversible																
LMP24 HR011-10	M6	3/8	10	7	5	4	860	1.0	2.2	210	18	11	23	1/4	1	8431 0245 85
LMP24 HR005-10	M8	3/8	22	16	10	7	380	1.0	2.2	210	18	11	23	1/4	1	8431 0245 77
LMP24 HR003-13	M8	1/2	30	22	14	10	250	1.2	2.6	210	18	11	23	1/4	1	8431 0245 91
LMP24 HR002-13	M10	1/2	40	33	20	15	180	1.3	2.9	230	21	11	23	1/4	2	8431 0245 70
LMP61 HR100-13	M12	1/2	100	75	60	45	2200	3.0	6.6	235	30	20	42	3/8	3	8431 0804 04
LMP61 HR170-13	M14	1/2	170	125	100	75	1400	3.0	6.6	238	30	20	42	3/8	3	8431 0804 11
LMP61 HR230-19	M16	3/4	230	170	130	95	1000	3.0	6.6	275	34	20	42	3/8	3	8431 0804 18
LMP61 HR350-20	M18	3/4	350	260	200	145	650	3.9	8.6	275	34	20	42	3/8	4	8431 0804 25
LMP61 HR500-20	M20	3/4	500	370	300	220	450	3.9	8.6	320	35	21	42	3/8	4	8431 0804 32
LMP61 HR700-25	M22	1	700	520	400	295	350	4.5	9.9	305	34	20	42	3/8	5	8431 0804 39
LMP61 HR900-25	M24	1	900	665	500	365	260	4.5	9.9	305	34	20	42	3/8	5	8431 0804 46
LMP61 HR1500-25	M30	1	1600	1180	900	660	140	6.8	14.9	345	42	20	42	3/8	9	8431 0804 53

^a Weight excluding reaction bar.

NOTE: Change over torque is around 4% of maximum torque on a given air pressure.

Recommended hose (61 series) size 13 mm for hose length up to 5 m and 16 mm hose size for length 5-10 m.

Shut-off

Pistol Grip Nutrunners

- LTP61 models are equipped with twin motors and a shut-off valve to ensure that the tool shuts off when the preset torque level is reached.
- Rundown is twice as fast as the LTP51.
- High torque accuracy.
- Extremely high torque output to weight ratio.
- A reversible tool with fixed positions for both forward and reverse.



LTP61 H900-25

Model	Bolt size mm	Square drive in	Torque range at 6.3 bar		Min torque at 3 bar		Free speed r/min	Weight ^a		Length mm	CS distance mm	Air consumption at free speed		Air inlet thread	Spline type	Ordering No.
			Nm	ft lb	Nm	ft lb		kg	lb			l/s	cfm			
Non reversible																
LTP61 H100-13	M12	1/2	55-100	40-75	45	35	1800	3.0	6.6	223	29	20	42	3/8	3	8431 0800 07
LTP61 H170-13	M14	1/2	95-170	70-125	70	50	1100	3.0	6.6	223	29	20	42	3/8	3	8431 0800 14
LTP61 H230-19	M16	3/4	125-230	90-170	85	60	820	3.0	6.6	223	29	20	42	3/8	3	8431 0800 21
LTP61 H350-20	M18	3/4	190-350	140-255	145	105	520	3.9	8.6	260	31	20	42	3/8	4	8431 0800 28
LTP61 H500-20	M20	3/4	275-500	200-370	220	160	360	3.9	8.6	260	31	20	42	3/8	4	8431 0800 35
LTP61 H700-25	M22	1	360-650	265-480	280	207	280	4.5	9.9	305	34	20	42	3/8	5	8431 0800 42
LTP61 H900-25	M24	1	480-870	350-640	300	220	210	4.5	9.9	282	32	20	42	3/8	5	8431 0800 49
LTP61 H1500-25	M30	1	850-1500	625-1100	700	516	115	6.8	14.5	323	42	20	42	3/8	9	8431 0800 56
Reversible																
LTP61 HR100-13	M12	1/2	55-100	40-75	45	35	1800	3.0	6.6	235	30	20	42	3/8	3	8431 0801 08
LTP61 HR170-13	M14	1/2	95-170	70-125	70	50	1100	3.0	6.6	238	30	20	42	3/8	3	8431 0801 15
LTP61 HR230-19	M16	3/4	125-230	90-170	85	60	820	3.0	6.6	275	34	20	42	3/8	3	8431 0801 22
LTP61 HR350-20	M18	3/4	190-350	140-255	145	105	520	3.9	8.6	275	34	20	42	3/8	4	8431 0801 29
LTP61 HR500-20	M20	3/4	275-500	200-370	220	160	360	3.9	8.6	275	34	20	42	3/8	4	8431 0801 36
LTP61 HR700-25	M22	1	360-650	265-480	280	207	280	4.5	9.9	305	34	20	42	3/8	5	8431 0801 43
LTP61 HR900-25	M24	1	480-870	350-640	300	220	210	4.5	9.9	305	34	20	42	3/8	5	8431 0801 50
LTP61 HR1500-25	M30	1	850-1500	625-1100	700	516	115	6.8	14.5	345	42	20	42	3/8	9	8431 0801 57
LTP61 HR1900-38	M30	1 1/2	1050-1900	770-1400	800	590	90	14.1	31.0	380	68	20	42	3/8	8	8431 0801 64
LTP61 HR2800-38	M36	1 1/2	1550-2800	1140-2060	1200	885	65	14.1	31.0	380	68	20	42	3/8	8	8431 0801 71
LTP61 HR3800-38	M42	1 1/2	2100-3800	1540-2800	1600	1180	50	14.1	31.0	380	68	20	42	3/8	8	8431 0801 78

^a Without reaction bar.

NOTE: Change over torque is around 4% of maximum torque on a given air pressure.

Recommended hose size 13 mm for hose length up to 5 m and 16 mm hose size for length 5-10 m.

Shut-off

Pistol Grip Nutrunners

FOR PREVAILING APPLICATIONS

- LTP61 PH is specially designed to handle prevailing applications, such as locking nuts.
- Special gear gives a higher change-over torque.
- Fast rundown motor handles most of the rundown before the slower but stronger tightening motor is used.



LTP61 PH900-25

Model	Bolt size mm	Square drive in	Torque range at 6.3 bar		Min torque at 3 bar		Free speed r/min	Weight ^a		Length mm	CS distance mm	Air consumption at free speed		Air inlet thread in	Spline type	Ordering No.
			Nm	ft lb	Nm	ft lb		kg	lb			l/s	cfm			
Non-reversible																
LTP61 PH100-13	M12	1/2	60-110	45-80	45	33	700	3.0	6.6	223	34	20	42	3/8	3	8431 0807 04
LTP61 PH170-13	M14	1/2	100-180	75-135	70	52	440	3.0	6.6	223	34	20	42	3/8	3	8431 0807 12
LTP61 PH230-19	M16	3/4	130-240	95-180	90	66	320	3.0	6.6	223	34	20	42	3/8	3	8431 0807 17
LTP61 PH350-20	M18	3/4	210-370	155-275	150	110	200	3.9	8.6	260	34	20	42	3/8	4	8431 0807 24
LTP61 PH500-20	M20	3/4	300-520	220-380	200	150	140	3.9	8.6	260	34	20	42	3/8	4	8431 0807 31
LTP61 PH700-25	M22	1	400-680	295-500	280	205	100	4.5	9.9	305	34	20	42	3/8	5	8431 0807 38
LTP61 PH900-25	M24	1	500-900	370-665	350	260	80	4.5	9.9	282	34	20	42	3/8	5	8431 0807 41
LTP61 PH1500-25	M30	1	900-1600	665-1180	650	480	45	6.8	14.9	323	42	20	42	3/8	9	8431 0807 52
Reversible																
LTP61 PHR700-25	M22	1	400-680	295-500	280	205	100	4.5	9.9	305	34	20	42	3/8	5	8431 0807 55
LTP61 PHR900-25	M24	1	500-900	370-665	350	260	80	4.5	9.9	305	34	20	42	3/8	5	8431 0807 62
LTP61 PHR1500-25	M30	1	900-1600	665-1180	650	480	45	6.8	14.9	345	42	20	42	3/8	9	8431 0807 68
Reversible with Multi Torque unit																
LTP61 PHR900-25-MT	M24	1	500-900	370-665	350	260	80	4.8	10.6	305	34	20	42	3/8	5	8431 0807 81

^a Without reaction bar.

Recommended hose size 13 mm for hose length up to 5 m and 16 mm hose size for length 5-10 m.

NOTE: Change over torque is around 10% of maximum torque on a given air pressure.

Shut-off

Pistol Grip Nutrunners

LTP WITH MULTITORQUE SELECTOR

- The Multi Torque Selector makes it possible to preset up to four different shut-off levels.
- The Rotary dial mounted on the tool allows the operator to select different torque levels without changing the tool.
- Ideal for situations where:
 - Several different assembly operations take place.
 - Multi-stage tightening operations are required.
 - Several different torque settings are needed.
- Reverse function that has fixed positions for both forward and reverse.



LTP61 HR900-25-MT

Model	Bolt size mm	Square drive in	Torque range at 6.3 bar		Min torque at 3 bar		Free speed r/min	Weight ^a		Length mm	CS distance mm	Air consumption at free speed		Air inlet thread in	Spline type	Ordering No.
			Nm	ft lb	Nm	ft lb		kg	lb			l/s	cfm			
LTP61 HR100-13-MT	M12	1/2	55-100	40-75	45	35	1800	3.3	7.3	273	30	20	42	3/8	3	8431 0806 02
LTP61 HR170-13-MT	M14	1/2	95-170	70-125	70	50	1100	3.3	7.3	273	30	20	42	3/8	3	8431 0806 09
LTP61 HR230-19-MT	M16	3/4	125-230	90-170	85	60	820	3.3	7.3	273	34	20	42	3/8	3	8431 0806 16
LTP61 HR350-20-MT	M18	3/4	190-350	140-255	145	105	520	4.2	9.2	310	34	20	42	3/8	4	8431 0806 23
LTP61 HR500-20-MT	M20	3/4	275-500	200-370	220	160	360	4.2	9.2	310	34	20	42	3/8	4	8431 0806 30
LTP61 HR700-25-MT	M22	1	360-650	265-480	280	207	280	4.8	10.6	340	34	20	42	3/8	5	8431 0806 33
LTP61 HR900-25-MT	M24	1	480-870	350-640	300	220	210	4.8	10.6	340	34	20	42	3/8	5	8431 0806 37
LTP61 HR1500-25-MT	M30	1	850-1500	625-1100	700	516	115	7.1	15.6	379	42	20	42	3/8	9	8431 0806 44

^a Without reaction bar.

Recommended hose size 13 mm for hose length up to 5 m and 16 mm hose size for length 5-10 m.

NOTE: Change over torque is around 4% of maximum torque on a given air pressure.

Productivity Kits

Model	Max air flow	Hose, 5 m	Coupling	Lubrication	Ordering No.
For small nutrunners with 3/8" BSP air inlet MIDI Optimizer F/RD EQ08-C10	16 l/s	Cabclair 10 mm	ErgoQIC 08	Yes	8202 0850 07
For small nutrunners with 1/4" BSP air inlet MIDI Optimizer F/RD EQ08-C10	16 l/s	Cabclair 10 mm	ErgoQIC 08	Yes	8202 0850 03
MIDI Optimizer F/RD EQ10-R10	16 l/s	Rubair 10 mm	ErgoQIC 10	Yes	8202 0850 16
For nutrunners with 3/8" BSP air inlet MIDI Optimizer F/RD EQ10-C13	23 l/s	Cabclair 13 mm	ErgoQIC 10	Yes	8202 0850 02
For nutrunners with 1/4" BSP air inlet MIDI Optimizer F/RD EQ10-C13-1/4	23 l/s	Cabclair 13 mm	ErgoQIC 10	Yes	8202 0850 11
For nutrunners with 3/8" BSP air inlet MIDI Optimizer F/RD EQ10-T13	35 l/s	Turbo 13 mm	ErgoQIC 10	Yes	8202 0850 17
For nutrunners with 1/2" BSP air inlet MIDI Optimizer F/R EQ10-T13	35 l/s	Turbo 13 mm	ErgoQIC 10	No	8202 0850 04
MIDI Optimizer F/RD EQ10-T13	35 l/s	Turbo 13 mm	ErgoQIC 10	Yes	8202 0850 13

Accessories Included

FOR LMP24

Suspension yoke,
reaction bar

FOR LMP/LTP61

Suspension yoke
Protective cover
For LTP61 HR1900, 2800, 3800 reaction arm

Optional Accessories

FOR LMP24

Model	Ordering No.
Hose nipple	9000 0247 00
Swivel attachment	4210 2249 80
Exhaust hose	4210 2053 00
Support handle (for H/HR002 only)	4110 1355 82
Spindle extension 115 mm x 1/2" (for H/HR002 only)	4210 2154 80
50 mm x 3/8" (for H/HR011/005 only)	4210 2158 80
1/4" hex bit holder (for H/HR011/005 only)	4021 0443 00
1/2" square adapter (for H/HR011/005 only)	4210 2157 80

FOR LMP/LTP61

Model	Ordering No.
Hose nipple	9000 0242 00
Exhaust hose	4210 2201 00
Protective cover Standard LTP61	4210 4672 00
LTP 61 with MT unit	4210 4672 01
Multi torque selector LTP61	4210 4636 95
Quick change retainer – 1/2" square models	4250 1190 00
– 3/4" square models	4210 3476 80
– 1" square models	4210 3524 80
Shut-off override for LTP61	4210 3545 80
Swivelling type MultiFlex connector 3/8" (BSP)	8202 1350 22
Swivelling type MultiFlex connector 3/8" (NPT)	8202 1350 28



Multi torque selector LTP61



Protective cover

SWIVELLING SUSPENSION YOKE LMP/LTP61

Model	Ordering No.
Mounting dia Ø 54 mm PH/H 100-13 PH/H 170-13 PH/H 230-19 PH/H 350-20 PH/H 500-20 PH/H 700-25 PH/H 900-25	4210 3088 80
Mounting dia Ø 60 mm HR 100-13 HR 170-13 HR 230-19	4210 3088 84

Model	Ordering No.
Mounting dia Ø 63.5 mm H 1900-38 H 2800-38 H 3800-38	4210 3088 83
Mounting dia Ø 67 mm HR 350-20 HR 500-20 PHR/HR 700-25 PHR/HR 900-25	4210 3088 82
HR 1900-38 HR 2800-38 HR 3800-38	4210 3088 85

Model	Ordering No.
Mounting dia Ø 83.5 mm PH/H 1500-25 PHR/HR 1500-25	4210 3088 81

Pistol Grip Nutrunners

Accessories LMP/LTP

REACTION BARS LMP/LTP 61

Spline dia mm	Square drive size mm/in	CC distance mm	Ordering No.
Steel bar			
Spline 1	268/36/18		4210 1798 01
Spline 2	270/35/10		4220 1903 00
Spline 3	400/56/12		4210 2219 80
Spline 4	500/62/15		4210 2183 80
Spline 5	500/62/15		4210 2726 80
Spline 6	560/80/15		4220 1200 01
Spline 8	500/150/20		4210 3899 03
Spline 9	500/85/20		4210 3899 80
Square steel bracket			
Spline 3	100/50/12		4210 2219 03
Spline 4	125/65/16		4210 2183 01
Spline 5	125/65/16		4210 2726 01
Spline 6	200/100/15		4220 1200 00
Spline 7	250/150/20		4220 1445 00
Spline 8	250/160/20		4220 1972 91
Spline 9	150/85/20		4210 3899 01
Triangular steel bracket			
Spline 2	73/72/14		4220 2137 02
Spline 3	82/80/15		4220 2137 03
Spline 6	112/109/15		4220 2137 06
Spline 6	150/145/20		4220 2137 16
Sliding drive reaction bar			
Spline 3	1/2	70-120	4210 4481 83
Spline 3	3/4	70-120	4210 4481 63
Spline 3	1/2	82-218	4210 4616 83
Spline 3	3/4	82-218	4210 4616 63
Spline 4	3/4	76-126	4210 4481 84
Spline 4	3/4	82-218	4210 4616 84
Spline 5	1	80-125	4210 4481 85
Spline 5	1	82-218	4210 4616 85
Spline 9	1	80-130	4210 4481 89
Spline 9	1	80-280	4210 4616 89
S-Type reaction bar			
Spline 3	110/18/12		4210 4480 03
Spline 4	120/22/15		4210 4480 04
Spline 5	130/25/15		4210 4480 05
Spline 6	125/25/15		4210 4480 06
Spline 8	200/65/20		4210 4480 08
Spline 9	160/40/20		4210 4480 09
L-Type aluminum bar			
Spline 3	266x300/29/15		4210 2219 08
Spline 4	144x150/42/15		4210 2183 08
Straight aluminum bar			
Spline 3	L = 400		4210 2219 01
Extended sliding drive reaction bar			
Spline 5	1	68-112	4210 4498 80
Extended sliding tube reaction bar			
Spline 5	1	68-112	4210 4498 82
Bracket stepped			
Spline 1	70/36/13		4210 1798 02
Spline 2	70/41/14		4210 2134 02

Steel bar



Square steel bracket



Triangular steel bracket



Sliding drive reaction bar



S-Type reaction bar



L-Type aluminum bar



Straight aluminum bar



Extended sliding drive reaction bar



Extended sliding tube reaction bar



Bracket stepped



Service Kits

Model	Trigger kit	General service kit
LMP24	4210 1934 91	4081 0105 90
LMP/LTP61	4210 2190 91	4081 0397 90

RTP NUTRUNNERS FOR HEAVY DUTY BOLTING

- RTP's slim gearpack gives you effortless access to bolts in cramped spaces.
- The torque output of the RTP is adjusted with an Atlas Copco FRL air pressure unit, helping to prolong the lifetime and torque accuracy of the tool.
- The tool's 1" exchangeable drive simplifies maintenance and cuts repair costs.



RTP4100



RTP1300

Model	Bolt size mm	Square drive in	Min torque at 1.5 bar		Max torque at 6.3 bar		Free speed r/min	Weight ^a		Length mm	CS distance mm	Air consumption at free speed		Rec. hose size mm	Air inlet thread in	Ordering No. ^b
			Nm	ft lb	Nm	ft lb		kg	lb			l/s	cfm			
RTP1300-HR20	20-27	3/4	320	235	1300	960	20	3.7	8.2	248	32	23	48.7	13	3/8	8431 1013 10
RTP4100-HR25	30-45	1	1000	738	4100	3100	10	8.7	19.2	335	41	31	65.5	13	3/8	8431 1040 10

^aWeight excluding reaction bar. ^bKit with included accessories, reaction bar, nipple and FRL stand.

Included Accessories

Model	Description	Ordering No.
RTP1300	Reaction bar, S-type	4210 4480 90
RTP4100	Reaction bar, S-type	4210 4480 93
RTP1300 / 4100	Nipple, ErgoNIP 10, M10, BSP	8202 1220 19
	Productivity kit FRL stand, BSP ^b	9090 3030 02

^bHose included.

Optional Accessories

Model	Description	Ordering No.
RTP1300 / 4100	MultiFlex swivel 3/8 BSP	8202 1350 22
	Trigger guard	4210 4759 90
RTP1300	Reaction bar, sliding-drive	4210 4752 90
	Reaction bar, steel bar	4210 4757 90
	Reaction bar, square bracket	4210 4758 90
RTP4100	Reaction bar, sliding-drive	4210 4752 91
	Reaction bar, steel bar	4210 4757 91
	Reaction bar, square bracket	4210 4758 91

NOTE: All reaction bars includes a snap ring



Service Kits

Model	Description	Ordering No.
RTP1300	Gear / Motor housing	4082 0125 90
	Gear / Motor / Motor housing	4081 0510 90
RTP4100	Gear / Motor housing	4082 0116 91
	Gear / Motor / Motor housing	4081 0504 90



Reaction bar, S-type



Productivity kit



Reaction bar, sliding-drive



Reaction bar, steel bar



Reaction bar, square bracket