

Grinders

Contents

Introduction.....	203
Guide.....	204
Product safety.....	205
Turbine grinders and sanders.....	206
Die grinders.....	209
Straight grinders.....	211
Vertical grinders.....	214
Vertical sanders.....	216
Angle grinders.....	218
Angle sanders.....	220
Belt sanders.....	222
Orbital and random orbital sanders.....	223
Dust extraction.....	225
Routers.....	228
Circular cutters.....	229



Maximum material removal with minimum effort

Atlas Copco Turbine Grinders give you twice the power with half the weight and are impossible to stall with the right installation! Atlas Copco's range covers all, you can rely on maximum material removal with minimum effort.

DIE GRINDING

Small precision deburring – die grinding is performed with either tungsten carbide, high speed steel burrs or mounted points.

The choice of burr depends on the size of your job. A larger volume of removed material will require a bigger size of the burr's head.

Select the tool r/min depending on the diameter of the burr head, the material to be ground and the material in the rotary burr. Use tungsten carbide burrs for hard and tough materials. High speed steel burrs are recommended for unhardened and medium hard materials. Example, see table below:

Burr head Ø		Hardened steel Tough materials	Unhardened steel	Soft material
			Softer materials Cast iron	Wood, brass Plastics, Al.
Up to 6 mm	– TC	38000	38000	38000
	– HSS	–	20000	20000
Up to 12 mm	– TC	30000	30000	30000
	– HSS	–	–	20000

TC – Tungsten carbide tipped rotary burr. HSS – High speed steel burrs.

For mounted points, follow the recommendations that relate to the particular mounted point.

ROUGH GRINDING

Pure material removal is determined by the power generated at the grinding process. The applied feed force and the rotation of the wheel generates a cutting force which, multiplied by the peripheral speed of the wheel, represents the power of removed material. (Power=Peripheral speed x Cutting force).

A powerful grinder will provide enough power with maintained rotational speed, when applying feed-force. A suitable combination of operative rotational speed, feed-force applied by the operator and power of the grinder, will give you the best combination for the material removal required.

As rough grinding is performed with bonded abrasives, a limitation of rotational speed is necessary in order to prevent wheel fractures due to centrifugal force.

The peripheral speed is limited to 80 m/s for fibre reinforced depressed center, straight and cutting off wheels. Resin bonded cup and straight wheels are limited to a peripheral speed of 50 m/s.

SANDING AND POLISHING

Unlike die and rough grinding, sanding and polishing applies to requirements of a surface. A fine surface will require a fine grit paper, fine Scotch-Brite, Bear Tex or a soft polishing bonnet. Rougher surface grinding will require a higher material removal rate and thus a coarser grit paper.

Similar to rough grinding, a rough surface, ground with coarse grit will benefit from a high rotational speed. The limitations are, however, the maximum allowed speed of the backing pad and the fibre disc.

Normal sanding speeds for fibre discs of diameter 125 mm, 180 mm and 230 mm are 4000 to 6000 r/min.

Polishing with different pastes and compounds requires low speed in combination with high torque. Suitable speeds are 1800 to 2200 r/min.

Sanding with wet coated abrasives is best performed at low speeds, partly because water is thrown out into the periphery and partly because of the fine grit.

Scotch-Brite, Bear Tex and flap wheels perform best at 50% of their maximum allowed rotational speeds.

THE SPEED GOVERNOR

The amount of material removed in the grinding process depends on the power of the tool and the operative rotational speed. The diagram below shows the correlation between torque, power and rotational speed of a non governed pneumatic grinder.

In order to remove material, the operator has to apply a feed-force on the work-piece. Consequently the rotational speed decreases and having passed approximately 50% of the free speed, the operative power outtake starts to decrease. Theoretically, the most material would be removed at approximately 50% of the free speed on a non governed grinder, (diagram 1).

Atlas Copco grinders are compact and smooth running, partly due to their speed governor. The air is governed to the air flow necessary to maintain the rotational speed regardless of load (to the extent of the power of the grinder).

The correlation between power, torque and rotational speed of a governed grinder is shown in diagram 2.

A theoretical optimum of material removal is reached at approximately 80% of the free speed. The grinder generates maximum power, removing more material with applied feed force. The rotational speed decreases negligibly.

Air is used economically, as the flow through the motor is adjusted after applied load. Air consumption at free speed is minimized. The governor opens and lets in more air during load thus keeping the optimal r/min.

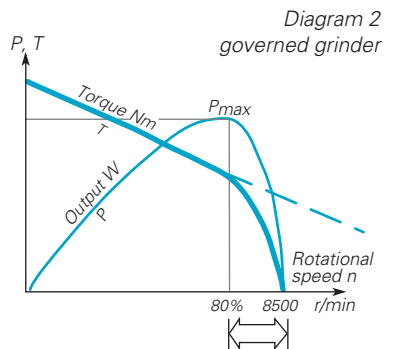
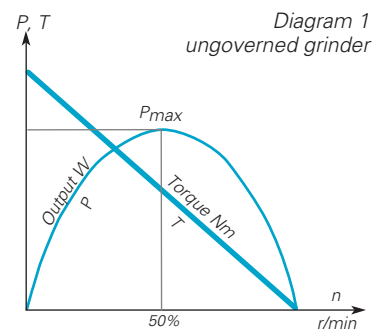

Guides

DIE GRINDING AND DEBURRING

SEE PAGE 209

1 Carbide burrs



2 Mounted points



ROUGH GRINDING AND CUTTING OFF

SEE PAGE 206, 207, 211 AND 214

3 Depressed center wheels



4 Cut off wheels



5 Cup wheels



6 Flap wheels



7 Straight wheels



8 Cone wheels

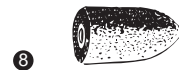

SANDING AND POLISHING

SEE PAGE 216, 220 AND 223

9 Fibre discs

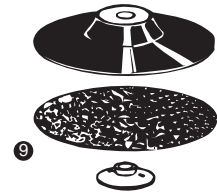

10 Wire brushes



11 Coated abrasives

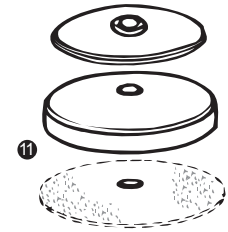

12 Polishing bonnets

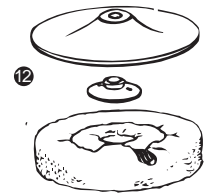

13 Radial flap wheels

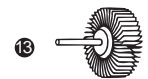

14 Scotch-Brite

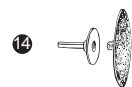

DIAMETER – PERIPHERAL SPEED – R/MIN

The table below will help you to translate the peripheral speed of the grinding wheel to the correct rotational speed of the grinder when using a grinding wheel with a specific diameter.

Grinding wheel dia mm	Peripheral speed in meters per second													
	10	15	20	25	28	30	33	35	40	45	48	50	60	80
25	7640	11460	15280	19100	21390	22920	25210	26740	30560	34380	36670	38200	45840	61120
40	4770	7160	9550	11930	13370	14320	15750	16710	19100	21480	22920	23870	28650	38200
50	3820	5730	7640	9550	10690	11460	12600	13370	15280	17190	18330	19100	22920	30560
63	3303	4540	6060	7560	8480	9090	10000	10610	12120	13640	14550	15150	18190	24250
80	2380	3580	4770	5960	6680	7160	7870	8350	9550	10740	11460	11930	14320	19100
100	1910	2860	3820	4770	5340	5730	6300	6680	7640	8590	9160	9550	11460	15280
115	1660	2490	3320	4150	4650	4980	5480	5810	6640	7470	7970	8300	9960	13400
125	1520	2290	3050	3820	4270	4580	5040	5340	6110	6870	7330	7640	9160	12280
150	1270	1910	2540	3180	3560	3820	4200	4450	5090	5730	6110	6360	7640	10180
180	1060	1590	2120	2650	2970	3180	3500	3710	4240	4770	5090	5300	6360	8480
200	950	1430	1910	2380	2670	2860	3150	3340	3820	4290	4580	4770	5730	7640
230	830	1240	1660	2070	2320	2490	2740	2900	3320	3730	3980	4150	4980	6640
250	760	1140	1520	1910	2130	2290	2520	2670	3050	3430	3660	3820	4580	6110
300	630	950	1270	1590	1780	1910	2100	2220	2540	2860	3050	3180	3820	5090

THIS IS YOUR RESPONSIBILITY

Always read and understand the safety information supplied with the tool and on www.atlascopco.com. All locally legislated safety rules regarding installation, operation and maintenance shall be respected at all times.

1. Check the free speed

- The measured speed at a pressure of 6.3 bars must not exceed the rated speed, which is marked on the grinder.
- Remove the grinding wheel and outer flange before checking the free speed.
- Carry out checks daily.
- Make sure the speed marking on the tool is legible.
- Return the machine for repair in the event of overspeeding.



2. Check the wheel guard

The wheel guard protects your health and safety.

- Always use the recommended wheel guard.
- Check that it is not damaged.
- Never use a grinder without the wheel guard.
- Position the wheel guard between yourself and the grinding wheel.



Check that the trigger is working correctly.

- The trigger must never be removed or fixed by tape for example.
- If the trigger is not working properly, make sure that it is replaced.

3. Maximum speed

Make sure that the stated maximum speed of the grinding wheel is greater than or equal to the speed specified on the grinder.

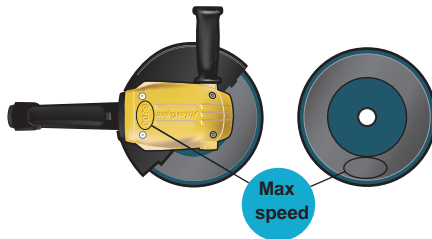

4. Check the grinding wheel

Make sure that the grinding wheel is not cracked or damaged in any way.

- The grinding wheel should have the correct hole dimensions and be fitted correctly on the spindle to avoid unbalanced vibrations.
- Damaged grinding wheels must be removed and replaced immediately.
- Do not use dropped or damaged wheels, as these can cause serious injuries.

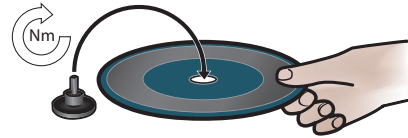

5. Check the flange and wheel

Make sure that flange and wheel combinations correspond to national regulations.

- Check that the flanges are undamaged and clean.
- Attach the wheel with the recommended torque.
- Always disconnect the air-supply when changing the wheel or adjusting the tool.
- Test-run your grinder in a protected area after assembling the wheel.
- Check that the grinder is working correctly.



6. Personal protection equipment

Make sure that operators wear:

- Eye protection, goggles or a visor.
- Ear protection.
- Gloves.
- Steel toe-capped shoes.
- Protective clothing, such as a leather apron.
- A helmet (for heavier applications).
- Avoid loosely hanging clothing, hair, jewellery (risk of getting caught).



7. Working area

Ensure that the area in which you are working is kept free from other people so that no one can get injured.

- People nearby must also wear hearing and eye protection.
- Check that there is good ventilation and dust extraction from the premises.
- There should be a stand or a place available, on which the machine can be safely placed.
- Work within a sealed-off area, if possible with protecting walls, since there is a risk that broken discs could fly off.

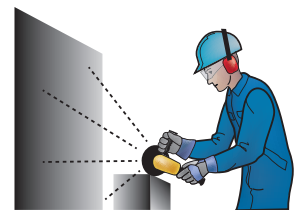

During work

Stop using the grinder if abnormally loud noises and vibrations occur during use. The grinder and its accessories must not be modified in any way.

After the work is finished

Make sure the machine is switched off and has come to a complete stop before it is put down. Put down the tool carefully, so that there is no risk of the tool starting by itself.



Maintenance

Make sure you follow the service instructions provided and the recommended service intervals. Do not dismantle safety-related parts such as the speed governor and overspeed shut off. These parts should be completely replaced when damaged.

TURBINE TECHNOLOGY BOOSTS PRODUCTIVITY

More efficient than a conventional vane grinder motor, the 2 stage turbine motor in the GTG25 provides an extremely high efficiency leading to great rate of material removal on the roughest surfaces. A speed governor ensures optimum process speed and process time is cut to a minimum. Since the job is done faster, the total energy consumption is significantly lower for each job.

REDUCES OPERATOR STRAIN

The GTG25 is ergonomically designed in every aspect. Its high power-to-weight ratio, 2.5 kW of power in a 2.1 kg tool, makes grinding much easier for the user. Combined with other GTG25 features, for example, an ergonomic angled throttle handle and an autobalancer to minimize vibrations, the overall result is less strain on the operator.



GTG25 F120-13



GTG25 F085-18

HIGHLY SERVICE FRIENDLY

With its all-metal design, the GTG25 turbine grinder is a robust, durable tool. Service intervals are long and servicing is easy thanks to modular internal components and Service Kits from Atlas Copco.

Model	Max free speed r/min	For wheel dia		Spindle thread	Max output		Weight		Height over spindle		Air consumption at free speed				Rec. hose size		Air inlet thread BSP	Ordering No.
		mm	in		kW	hp	kg	lb	mm	in	l/s	cfm	l/s	cfm	mm	in		
For grinding and cutting off																		
GTG25 F120-13	12000	125	5	–	2.5	3.4	2.1	5.07	59	2.3	32	67.8	9	19	16	5/8	3/8	8423 2525 01
GTG25 F120-M14	12000	125	5	M14	2.5	3.4	2.1	5.07	59	2.3	32	67.8	9	19	16	5/8	3/8	8423 2525 10
GTG25 F120-5/8	12000	125	5	UNC 5/8"	2.5	3.4	2.1	5.07	59	2.3	32	67.8	9	19	16	5/8	3/8	8423 2525 12
GTG25 F085-18	8500	180	7	–	2.5	3.4	2.2	5.29	59	2.3	32	67.8	9	19	16	5/8	3/8	8423 2525 02
GTG25 F085-M14	8500	180	7	M14	2.5	3.4	2.2	5.29	59	2.3	32	67.8	9	19	16	5/8	3/8	8423 2525 11
GTG25 F085-5/8	8500	180	7	UNC 5/8"	2.5	3.4	2.2	5.29	59	2.3	32	67.8	9	19	16	5/8	3/8	8423 2525 13
For wire brush																		
GTG25 F085-13	8500	125	5	–	2.5	3.4	2.1	5.07	59	2.3	32	67.8	9	19	16	5/8	3/8	8423 2525 15
For sanding																		
GTG25-S085	8500	180	7	5/8-11	2.5	3.4	2.0	4.4	59	2.3	32	67.8	9	19	16	5/8	3/8	8423 2525 03
GTG25-S085-M14	8500	180	7	M14	2.5	3.4	2.0	4.4	59	2.3	32	67.8	9	19	16	5/8	3/8	8423 2525 04
GTG25-S060	6000	230	9	5/8-11	2.5	3.4	2.0	4.4	59	2.3	32	67.8	9	19	16	5/8	3/8	8423 2525 20
GTG25-S060-M14	6000	230	9	M14	2.5	3.4	2.0	4.4	59	2.3	32	67.8	9	19	16	5/8	3/8	8423 2525 21

Accessories

TOOL ACCESSORIES

Model	Ordering No.
Whip-hose (incl.)	4175 0738 90
Deflector kit (incl.)	4175 0667 90
Exhaust hose	4150 1532 95
Flange center depressed wheel (incl.)	4175 0777 90
Flange cut off (incl.)	4175 0777 92
Spot suction kit for sander	3780 4090 27

SPOT SUCTION KIT

	Ordering No.
Spot suction kit for diamond cutting wheel Ø 180 mm	3780 4090 35
Spot suction kit for depressed center wheel Ø 180 mm	3780 4090 30
Add on spot suction Ø 125 mm	3780 4032 14
Ø 180-230 mm	3780 4032 12

AIR LINE ACCESSORIES

Model	Ordering No.
MultiFlex	8202 1350 22
Claw coupling	9000 0262 00
Blow protector	8202 0100 62
HM Open XL hose reel	8202 1183 39

Productivity Kits

Model	Air inlet BSP	Max air flow	Hose, 5 m	Coupling	Lubrication	Ordering No.
MAXI F/R C-T16	1/2	60 l/s	Turbo 16 mm	Claw	No	8202 0850 05

The GTG40 are the most powerful grinders in the turbine grinder range, with incredible power for their size and weight. The range includes angle and straight type grinders for virtually every common rough grinding application.

- GTG40 F – for rough grinding and cutting off with depressed center wheels.
- GTG40 S – for surface finishing with fibre discs and wire brushes.
- GTG40 C – for rough grinding with cup wheels.
- Dust extraction – Efficient accessory for extraction of air-borne dust in sanding applications with fiber discs.



GTG40 F066-23



GTG40 S060-C15



GTG40 F085-18



GTG40 S060

MORE EFFECTIVE

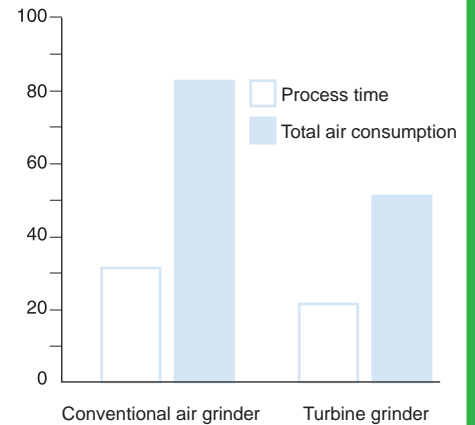

The turbine motor is more efficient than a conventional grinder motor. Therefore it takes less time to do the same job. Also the total air consumption will be a lot less for a specific job.

Model	Max free speed r/min	For wheel dia mm	Max output		Weight		Height over spindle		Air consumption at				Rec. hose size		Air inlet thread BSP	Ordering No.
			kW	hp	kg	lb	mm	in	max output l/s	free speed l/s	cfm	cfm	mm	in		
For grinding and cutting off																
GTG40 F085-18	8500	180	4.5	6.1	3.8	8.4	128	5.0	60	126	20	42	16	5/8	1/2	8423 2900 10
GTG40 F066-23	6600	230	4.5	6.1	4.0	8.8	128	5.0	60	126	20	42	16	5/8	1/2	8423 2910 10
For sanding with fibre disc and wire brush																
GTG40 S060	6000	140 ^a	4.5	6.1	3.6	7.9	132	5.2	60	126	20	42	16	5/8	1/2	8423 2930 00
For cup wheel type 11																
GTG40 S072-C13	7200	125	4.5	6.1	4.1	9.1	126	5.0	60	126	20	42	16	5/8	1/2	8423 2930 30
GTG40 S060-C15 ^b	6000	150	4.5	6.1	4.3	10.5	126	5.0	60	126	20	42	16	5/8	1/2	8423 2930 10

^a For wire brush, Ø 230 mm for fibre disc. ^b Spindle thread: UNC 5/8". Length 23.5 mm.

Accessories Included

GTG40

Adjustable wheel guard
 Support handle
 Attachments flanges for 1.5-7 mm thick cut-off wheels and 2.5-8 mm thick depressed center wheels
 Whip hose 0.7 m long, 16 mm dia complete with nipple and ErgoNIP 10
 Hex key for wheel change

Optional Accessories

GTG40

	Ordering No.
Heavy duty backing pad for sanding Ø 180 mm (7")	4170 1192 90
Ø 230 mm (9")	4170 1193 90
Hand shield	4175 0165 90
Adapter for positioning support handle 120/135° between handles	4175 0164 90 ^b
Adapter kit fibre disc	4175 0238 90
Dust extraction kit for 180 mm fiber disc GTG40 S060	3780 4090 11 ^a
Hose kit including 1.8 m vacuum hose, Ø 38 mm and air hose Ø 13 mm	3780 2724 41
Friction plate complete	4175 0186 90
Attachment for cup wheel with plane hole	4175 0178 90

^a Incl. flow chamber, suction cap and support pad.

^b Included as standard in GTG40 S060-C15.

GTG40

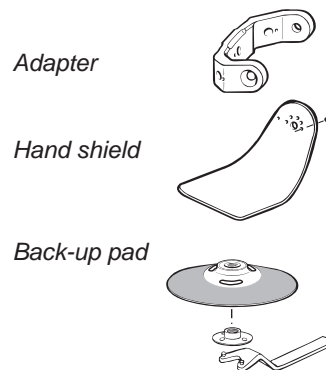

Productivity Kits

Model	Air inlet BSP	Max air flow	Hose, 5 m	Coupling	Lubrication	Ordering No.
MAXI F/R C-T16	1/2	60 l/s	Turbo 16 mm	Claw	No	8202 0850 05



Service Kits

GTG40	4081 0153 90
GTR40	4081 0153 91

- LSF07 is a high speed model for precision grinding and polishing. LSF07 is delivered with a 3 mm collet and can be equipped with a 1/8" collet as optional. (Without speed governor)
- LSF12/LSV12 – Small and comfortable die grinder with up to 360 W for maximum control in cramped spaces. All models are delivered with speed governor and a well balanced 6 mm Erickson collet.
- LSF19/LSV19 – All models in the 19 series are equipped with a powerful 0.5 kW air motor and a speed governor. The angled models (LSV) have a patented solution that overcomes temperature and leakage problems commonly associated with angle head tools. The result is a leak free and self-cooled angle head. All models are lubrication free except for the high speed model LSF19 S460.
- LSF29/LSV29 – Powerful 1 kW air motor, with speed governor and scatter damping. Impressive power-to-weight ratio.
- LSF39 – One of the most powerful one hand die grinders on the market, up to 1.8 kW. The die grinders in the 39 series are lubrication free with scatter damping for maximum operator comfort and safety.



Model	Max free speed r/min	Rec. max dia of		Max output kW	Max output hp	Weight kg	Length lb	Length mm	Air consumption at				Rec. hose size mm	Air inlet thread in	Collet size	Ordering No.	
		Tungsten carbide burrs mm	Mounted points mm						max output l/s	free speed cfm	l/s	cfm					
Straight die grinders																	
LSF12 S400-1 ^a	40000	9	16	0.36	0.48	0.4	0.8	170	9.8	20.8	7.0	14.8	8	5/16	1/4	6 mm	8423 1124 04
LSF12 S310-1	31000	12	20	0.32	0.43	0.4	0.8	170	9.2	19.5	4.2	8.9	8	5/16	1/4	6 mm	8423 1124 03
LSF12 S250-1 ^a	25000	12	20	0.29	0.39	0.4	0.8	170	8.5	18.0	3.4	7.2	8	5/16	1/4	6 mm	8423 1124 02
LSF12 S200-1 ^a	20000	12	20	0.24	0.32	0.4	0.8	170	8.1	17.2	2.6	5.5	8	5/16	1/4	6 mm	8423 1124 01
LSF19 S460E-1/R	46000	9	16	0.51	0.68	0.7	1.5	293	11.4	24.0	15.0	31.5	10	3/8	1/4	6 mm	8423 1224 90
LSF19 S460-1	46000	9	16	0.51	0.68	0.5	1.1	193	11.4	24.0	15.0	31.5	10	3/8	1/4	6 mm	8423 1224 82
LSF19 S460E-1	46000	9	16	0.51	0.68	0.7	1.5	293	11.4	24.0	15.0	31.5	10	3/8	1/4	6 mm	8423 1224 87
LSF19 S300-1	30000	12	20	0.50	0.67	0.5	1.1	193	11.3	23.7	6.6	13.8	10	3/8	1/4	6 mm	8423 1224 81
LSF19 S300-2	30000	12	20	0.50	0.67	0.5	1.1	193	11.3	23.7	6.6	13.8	10	3/8	1/4	1/4 in	8423 1224 84
LSF19 S300-1/R	30000	12	20	0.50	0.67	0.5	1.1	193	11.3	23.7	6.6	13.8	10	3/8	1/4	6 mm	8423 1224 89
LSF19 S300E-1	30000	12	20	0.50	0.67	0.7	1.5	293	11.3	23.7	6.6	13.8	10	3/8	1/4	6 mm	8423 1224 86
LSF19 S300E-1/R	30000	12	20	0.50	0.67	0.7	1.5	293	11.3	23.7	6.6	13.8	10	3/8	1/4	6 mm	8423 1224 88
LSF19 S200-1	20000	12	20	0.50	0.67	0.5	1.1	193	9.6	20.1	3.5	7.4	10	3/8	1/4	6 mm	8423 1224 80
LSF19 S200-2	20000	12	20	0.50	0.67	0.5	1.1	193	9.6	20.1	3.5	7.4	10	3/8	1/4	1/4 in	8423 1224 83
LSF19 S200E-1	20000	12	20	0.50	0.67	0.7	1.5	293	9.6	20.1	3.5	7.4	10	3/8	1/4	6 mm	8423 1224 85
LSF29 S120	12000	16	40	0.67	0.9	0.8	1.7	213	17.0	36.0	3.5	7.4	13	1/2	3/8	6 mm	8423 0127 00
LSF29 S120-HD R	12000	16	40	0.67	0.9	1.2	2.6	213	17.0	36.0	3.5	7.4	13	1/2	3/8	6 mm	8423 0127 23
LSF29 S120E-HD R	12000	16	40	0.67	0.9	1.6	3.5	332	17.0	36.0	3.5	7.4	13	1/2	3/8	6 mm	8423 0127 22
LSF29 S150	15000	16	40	0.79	1.1	0.8	1.7	213	18.0	38.1	4.4	9.3	13	1/2	3/8	6 mm	8423 0127 02
LSF29 S150E	15000	16	40	0.79	1.1	1.4	3.1	332	18.0	38.1	4.4	9.3	13	1/2	3/8	6 mm	8423 0127 04
LSF29 S180	18000	16	40	0.88	1.2	0.8	1.7	213	20.0	42.4	6.2	13.1	13	1/2	3/8	6 mm	8423 0127 05
LSF29 S180-HD R	18000	16	40	0.88	1.2	1.2	2.6	213	20.0	42.4	6.2	13.1	13	1/2	3/8	6 mm	8423 0127 25
LSF29 S180E	18000	16	40	0.88	1.2	1.4	3.1	332	20.0	42.4	6.2	13.1	13	1/2	3/8	6 mm	8423 0127 08
LSF29 S180E-HD R	18000	16	40	0.88	1.2	1.6	3.5	332	20.0	42.4	6.2	13.1	13	1/2	3/8	6 mm	8423 0127 24
LSF29 S250 ^a	25000	12	32	1.03	1.4	0.8	1.7	213	22.0	46.6	8.6	18.2	13	1/2	3/8	6 mm	8423 0127 11
LSF29 S250-HD R ^a	25000	12	32	1.03	1.4	1.2	2.6	213	22.0	46.6	8.6	18.2	13	1/2	3/8	6 mm	8423 0127 27
LSF29 S250E ^a	25000	12	32	1.03	1.4	1.4	3.1	332	22.0	46.6	8.6	18.2	13	1/2	3/8	6 mm	8423 0127 14
LSF29 S250E-HD R ^a	25000	12	32	1.03	1.4	1.6	3.5	332	22.0	46.6	8.6	18.2	13	1/2	3/8	6 mm	8423 0127 26
LSF39 S120E	12000	16	40	1.5	2.0	1.6	3.6	367	24.2	51.3	9.0	19.1	13	1/2	3/8	6 mm	8423 1233 00
LSF39 S150E	15000	16	40	1.7	2.3	1.6	3.6	367	27.6	58.5	12.1	25.6	13	1/2	3/8	6 mm	8423 1233 01
LSF39 S180E	18000	16	40	1.8	2.5	1.6	3.6	367	30.8	65.3	15.2	32.2	13	1/2	3/8	6 mm	8423 1233 02
LSF39 S250E ^a	25000	16	40	1.8	2.5	1.6	3.6	367	32.9	69.7	33.2	70.3	13	1/2	3/8	6 mm	8423 1233 03

^a Not lubrication-free.

E = Extended version R = Model is rigid, without scatter damping

Continued...

Model	Max free speed r/min	Rec. max dia of		Max output		Weight kg lb	Length mm	Air consumption at				Rec. hose size mm in	Air inlet thread BSP	Collet size	Ordering No.		
		Tungsten carbide burs mm	Mount-ed points mm					kW	hp	max output						free speed	
				l/s	cfm					l/s	cfm						
Angle die grinders																	
LSV12 S200-1 ^a	20000	12	20	0.29	0.39	0.5	1.2	166	9.5	20.1	6.4	13.6	8	5/16	1/4	6 mm	8423 1124 06
LSV12 S120-1 ^a	12000	12	20	0.24	0.33	0.5	1.2	166	8.3	17.6	3.0	6.4	8	5/16	1/4	6 mm	8423 1124 05
LSV19 S200-1	20000	12	20	0.46	0.62	0.6	1.3	185	11.3	23.9	7.5	15.9	10	3/8	1/4	6 mm	8423 0111 41
LSV19 S120-1	12000	12	20	0.46	0.62	0.6	1.3	185	11.3	23.9	7.5	15.9	10	3/8	1/4	6 mm	8423 0111 43
LSV19 S080-1	8000	12	20	0.37	0.50	0.6	1.3	185	11.3	23.9	6.5	13.8	10	3/8	1/4	6 mm	8423 0111 46
LSV28 S150	15000	16	40	0.68	0.91	1.2	2.5	250	17.0	36.0	8.3	17.6	10	3/8	3/8	6 mm	8423 0125 54
Grinders for polishing																	
LSF29 S030 R	3000	—	—	0.83	1.1	1.2	2.6	257	20.0	42.4	6.2	13.1	13	1/2	3/8	6	8423 0127 18
LSF29 S030E	3000	—	—	0.83	1.1	1.8	4.0	381	20.0	42.4	6.2	13.1	13	1/2	3/8	6	8423 0127 19
LSF29 S070 R ^a	7000	—	—	0.98	1.3	1.2	2.6	256	22.0	46.6	8.6	18.2	13	1/2	3/8	6	8423 0127 20
LSF29 S070E ^a	7000	—	—	0.98	1.3	1.8	4.0	381	22.0	46.6	8.6	18.2	13	1/2	3/8	6	8423 0127 21
High speed pen model																	
LSF07 S850	88000	4	6	0.10	0.10	0.4	0.9	173	2.2	4.9	2.3	4.6	4.5	3/16	—	3 mm	8423 1222 03

^a Not lubrication-free. E = Extended version R = Model is rigid, without scatter damping

Accessories Included

LSF07	LSF/LSV12	LSF/LSV19/28/29	LSF39
Air hose, ErgoNIP 08, Collet 3 mm (See ill 1.)	Spanner, Collet 6 mm (See ill. 1), Air hose, Air hose nipple and clamp, Exhaust hose	Spanner, Collet 6 mm (See ill. 1), Air hose, Air hose nipple and clamp, Exhaust hose	Air hose nipple, Collet 6 mm (See ill 1.)

Optional Accessories

	LSF07	LSF/LSV12	LSF/LSV19	LSF/LSV29	LSF39	See ill.
Optional collets						
Collet 1/8"	4150 1822 00	4150 2226 46	-	-	-	1
Collet 3 mm	4150 1800 00	-	4150 0081 00	4150 0081 00	-	1
Collet 6 mm	-	4150 2226 03	4150 0075 00	4150 0075 00	4150 1453 00	1
Collet 8 mm	-	-	4150 0074 00	4150 0074 00	4150 0706 00	1
Collet 1/4"	-	-	4150 0076 00	4150 0076 00	4150 1754 00	1
Collet 10 mm	-	-	-	-	4150 0681 00	1
Collar	-	4150 2226 02	-	-	-	7
Collet nut	-	4150 2226 04	4150 0760 00	4150 0760 00	4150 0849 00	3
Collet nut and holder	-	-	-	4110 0844 90	-	-
Extension 75 mm/3"	-	-	4150 0674 00 ^a	4150 0674 00 ^a	-	4
For machining of plastic and fibre glass						
Diamond burr Ø 6 mm	-	3780 5013 70	3780 5013 70	-	-	2
Diamond drum Ø 27 mm	-	-	3780 5033 00	-	-	5
Spot suction kit for burr (burr not incl.)	3780 3015 23	-	3780 3015 22	-	-	6
Spot suction kit for drum (drum not incl.)	-	-	3780 4011 61 ^b	-	-	6
Cone wheel adapter UNF 3/8	-	-	-	4150 2326 80 ^c	-	-
Cone wheel adapter UNC/W 5/8	-	-	-	4150 2292 85 ^c	-	-

^a Only for rigid (-R) models ^b For use with 6 mm collet ^c Only for extended (-E) models

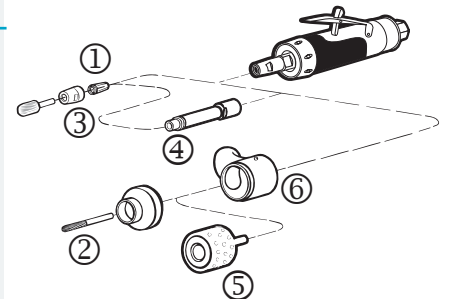

LSF07, LSF/LSV12

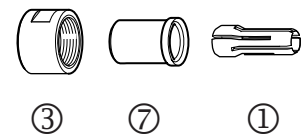

Productivity Kits

Model	Air inlet BSP	Max air flow	Hose, 5 m	Coupling	Lubrication	Ordering No.
MIDI Optimizer F/RD EQ10-R13-W, incl. whiphose	3/8	23 l/s	Rubair 13 mm	ErgoQIC 10	Yes	8202 0850 14
MIDI Optimizer F/RD EQ10-R13-W, incl. whiphose	—	23 l/s	Rubair 13 mm	ErgoQIC 10	Yes	8202 0850 15
MIDI Optimizer F/RD EQ10-T13	3/8	35 l/s	Turbo 13 mm	ErgoQIC 10	Yes	8202 0850 17
MIDI Optimizer F/R EQ10-T13	1/2	35 l/s	Turbo 13 mm	ErgoQIC 10	No	8202 0850 04
MIDI Optimizer F/RD EQ10-T13	1/2	35 l/s	Turbo 13 mm	ErgoQIC 10	Yes	8202 0850 13



Service Kits

07 series 4081 0243 90 12 series 4081 0472 90 19 series 4081 0486 90 29 series 4081 0581 00 39 series 4081 0581 03
210 Grinders

Atlas Copco straight grinders for cone wheel or collet, are suitable for grinding in holes and cavities in castings. They require rough abrasives, which must be attached to the tool with a rigid shank or to be mounted directly to the spindle.

The power ranges from 1.5 kW to 2 kW. All Atlas Copco tools are designed with focus on operator ergonomics and maximum power, the best combination for maximum productivity.

- If you need maximum power, then LSR48 is the natural choice. You will have access to 2 kW in combination with an autobalancer for even less vibrations.



Model	Max free speed r/min	Max output		Weight		Length mm	Air consumption at				Rec. hose size		Air inlet thread BSP	Ordering No.
							max output		free speed					
							kW	hp	kg	lb	l/s	cfm	l/s	
LSR48 S150-CW	15000	2.0	2.7	2.3	5.0	450	35.0	74.0	19.0	40.0	16	5/8	1/2	8423 1430 08
LSR48 S120-CW	12000	1.8	2.4	2.3	5.0	450	30.0	64.0	13.0	27.0	16	5/8	1/2	8423 1430 05
LSR48 S090-CW	9000	1.5	2.0	2.3	5.0	450	28.0	59.0	11.0	23.0	16	5/8	1/2	8423 1430 03

LSR48 has UNC 1/2" spindle for direct attachment of a cone wheel. For UNC 5/8" spindle or collet use an adapter (not included).

Accessories Included

Whip hose
Wrench



Service Kits

48 series 4081 2023 90

Optional Accessories

	See ill.	Ordering No.
Adapter for cone wheel with thread		
UNC/W 5/8"	4	4150 0945 01
Collet type		
Nut	1a	4150 0849 00
Collet Ø 6 mm	1b	4150 1453 00
Collet Ø 8 mm	1b	4150 0706 00
Collet Ø 9 mm	1b	4150 0765 00
Collet Ø 10 mm	1b	4150 0681 00
Collet Ø 1/4"	1b	4150 1754 00
Collet holder	1c	4150 0680 01

NOTE: Adapters are not included with the tool, and need to be ordered to attach a cone wheel.

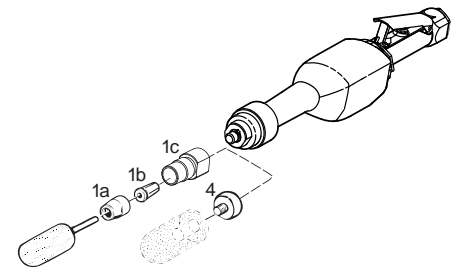

LSR48

Productivity Kits

Model	Air inlet BSP	Max air flow	Hose, 5 m	Coupling	Lubrication	Ordering No.
MIDI Optimizer F/R EQ10-T13	1/2	35 l/s	Turbo 13 mm	ErgoQIC 10	No	8202 0850 04
MIDI Optimizer F/RD EQ10-T13	1/2	35 l/s	Turbo 13 mm	ErgoQIC 10	Yes	8202 0850 13
MIDI Optimizer F/RD EQ10-T16	1/2	40 l/s	Turbo 16 mm	ErgoQIC 10	Yes	8202 0850 12

Atlas Copco straight grinders, equipped with a straight type 1 grinding wheel, offer a high rate of material removal in application like cutting and grinding of welds and edges.

The power ranges from 0.6 kW to 2.9 kW.

- The LSR28 is suitable for lighter applications where accessibility is first priority. Low sound and low vibration levels thanks to the unique vibration damping system. Thermally insulated throttle handle and piped away exhaust air are some of the LSR28 product features, all designed for the best comfort for the operator.
- LSR43 has a proven and rigid design, and is suitable for those really tough applications where durability is needed.
- If you need maximum power, then LSR48 or LSR64 is the choice. 2.9 kW in combination with auto balancer for even less vibrations (LSR48).



Model	Max free speed r/min	For wheel dia. DxTxH mm	Spindle thread and length	Max output		Weight		Length mm	Air consumption at				Rec. hose size		Air inlet thread BSP	Ordering No.
				kW	hp	kg	lb		max output l/s	free speed l/s	max output cfm	free speed cfm	mm	in		
LSR28 S180-05	18000	50x13x10	UNF 3/8x42	0.82	1.09	1.9	4.1	340	19.8	42.0	7.3	15.5	13	3/8	1/2	8423 1325 04
LSR28 S150-10	15000	100x13x20	UNC 1/2x42	0.70	0.94	2.2	4.8	340	18.0	38.2	5.8	12.3	13	3/8	1/2	8423 1325 02
LSR43 S150-10	15000	100x25x25	UNC 1/2x49	1.0	1.4	2.8	6.2	460	23.0	49.0	10.0	21.0	13	1/2	1/2	8423 1430 34
LSR43 S120-08	12000	80x25x13	UNC 1/2x49	0.9	1.2	2.5	5.5	460	20.0	42.0	7.0	15.0	13	1/2	1/2	8423 1430 26
LSR43 S090-10	9000	100x25x13	UNC 1/2x49	0.8	1.1	2.4	5.3	460	18.0	38.0	5.0	11.0	13	1/2	1/2	8423 1430 18
LSR48 S120-08 ^a	12000	80x25x13-25	UNC 1/2x37	1.8	2.4	3.0	6.6	498	30.0	64.0	13.0	28.0	16	5/8	1/2	8423 1430 04
LSR48 S120-10	12000	100x32x16-25	UNC 5/8x49	1.8	2.4	3.5	7.7	495	30.0	64.0	13.0	28.0	16	5/8	1/2	8423 1430 09
LSR48 S120-13	12000	125x25x16-25	UNC 5/8x42	1.8	2.4	3.6	7.9	487	30.0	64.0	13.0	28.0	16	5/8	1/2	8423 1430 06
LSR48 S090-10 ^a	9000	100x25x13-25	UNC 1/2x37	1.5	2.0	3.2	7.0	495	28.0	59.0	11.0	23.0	16	5/8	1/2	8423 1430 02
LSR64 S100-15	10000	150x25x16	UNC 5/8x55	2.9	4.0	5.8	2.8	535	53.0	112.0	26.0	55.0	16	5/8	1/2	8423 1640 55
LSR64 S072-13	7200	125x25x16	UNC 5/8x55	2.5	3.4	5.4	11.9	535	45.0	95.0	14.0	30.0	16	5/8	1/2	8423 1640 30
LSR64 S060-15	6000	150x25x16	UNC 5/8x55	2.3	3.1	5.4	11.9	535	41.0	87.0	11.0	23.0	16	5/8	1/2	8423 1640 22

DxTxH = Diameter x Thickness x Hole.

^a LSR48 S120-08 and LSR48 S090-10 are equipped with closed wheel guard.

Model	Max free speed r/min	Spindle thread and length	Max output		Weight		Length mm	Air consumption at				Rec. hose size		Air inlet thread BSP	Ordering No.	
			kW	hp	kg	lb		max output l/s	free speed l/s	max output cfm	free speed cfm	mm	in			
For wire brushes																
LSR64 S041	4100	UNC 5/8 x 55	1.6	2.5	5.4	11.9	535	29.0	61.0	7.0	15.0	16	5/8	1/2	8423 1640 14	

Accessories Included

LSR28

Wheel guard, size according to type
Nut, flanges
Air hose, air hose nipple and clamp
Exhaust hose
Wrenches

LSR43

Wheel guard, size according to type
Nut
Flanges
Pin key

LSR48

Whip hose
Hook wrench
Pin key
Wheel guard, size according to type
Flanges that suit wheels with inner diameter of 13/16/20 and 25 mm

LSR64

Wheel guard, size according to type
Nut, flanges
Air hose nipple and clamp
Wrenches

Optional Accessories

	LSR28	LSR64	See ill.
Rear flange, for 125-150x25x32 wheel	-	4150 0620 00	1
50-100x13x20 wheel	4150 1271 01	-	1
Spacer, to fit cone wheel	-	4150 0787 00	2

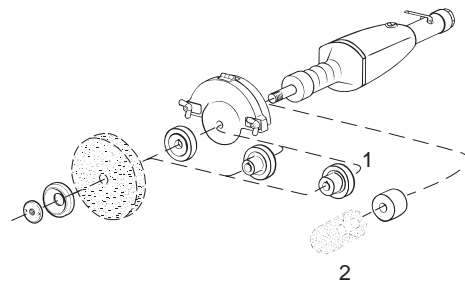

Productivity Kits

Model	Air inlet BSP	Max air flow	Hose, 5 m	Coupling	Lubrication	Ordering No.
MIDI Optimizer F/RD EQ10-R13-W, incl. whiphose	3/8	23 l/s	Rubair 13 mm	ErgoQIC 10	Yes	8202 0850 14
MIDI Optimizer F/RD EQ10-R13-W, incl. whiphose	-	23 l/s	Rubair 13 mm	ErgoQIC 10	Yes	8202 0850 15
MIDI Optimizer F/RD EQ10-T13	3/8	35 l/s	Turbo 13 mm	ErgoQIC 10	Yes	8202 0850 17
MIDI Optimizer F/R EQ10-T13	1/2	35 l/s	Turbo 13 mm	ErgoQIC 10	No	8202 0850 04
MIDI Optimizer F/RD EQ10-T13	1/2	35 l/s	Turbo 13 mm	ErgoQIC 10	Yes	8202 0850 13
MIDI Optimizer F/RD EQ10-T16	1/2	40 l/s	Turbo 16 mm	ErgoQIC 10	Yes	8202 0850 12
MAXI F/R C-T16	1/2	60 l/s	Turbo 16 mm	Claw	No	8202 0850 05



Service Kits

28 series	4081 0317 90
43 series	4081 0020 90
48 series	4081 2023 90
64 series	4081 0138 90

Vertical Grinders For Depressed Center, Cut-off and Cup Wheels

The rigid design with a vertically standing air moto gives impressively long service life and durability.

- LSS series is suitable for rough grinding and cutting off operations on open surfaces.
- The power is impressive and ranges from 1.4 kW to a massive 3.8 kW.
- LSS53 is equipped with a unique silencer that reduces the sound peaks created at start and shut-off.



Model	Max free speed r/min	For wheel dia mm	Spindle thread and length	Max output		Weight		Height over spindle mm	Air consumption at				Rec. hose size		Air inlet thread BSP	Ordering No.
				kW	hp	kg	lb		max output l/s	free speed cfm	l/s	cfm	mm	in		
LSS53 S072-C13	7200	125	UNC 5/8x30	1.3	1.8	3.1	6.8	180	26.0	55.0	8.0	17.0	13	1/2	1/2	8423 2534 12
LSS53 S085-18	8500	180	UNC 5/8x30	1.4	1.9	2.9	6.4	180	27.0	57.0	10.0	21.0	13	1/2	1/2	8423 2530 72
LSS64 S060-23	6000	230	UNC 5/8x31	2.2	3.0	5.1	12.6	201	40.0	85.0	9.0	19.0	16	5/8	1/2	8423 2641 46
LSS64 S060-C15	6000	150	UNC 5/8x31	2.2	3.0	5.0	11.0	201	40.0	85.0	9.0	19.0	16	5/8	1/2	8423 2641 04
LSS64 S085-18	8500	180	UNC 5/8x31	2.6	3.5	4.7	10.4	201	50.0	106.0	13.0	28.0	16	5/8	1/2	8423 2641 38
LSS84 S060-23	6000	230	UNC 5/8x32	3.8	5.1	6.0	13.2	217	65.0	138.0	17.0	36.0	19	3/4	1/2	8423 2840 26

- 13 = 125 mm wheel.
- 18 = 180 mm wheel.
- 23 = 230 mm wheel.
- C13 = 125 mm cup wheel.
- C15 = 150 mm cup wheel.

Accessories Included

Wheel guard	
Flange	4170 0758 01
Nut	4170 0220 01
Wrenches	

Optional Accessories

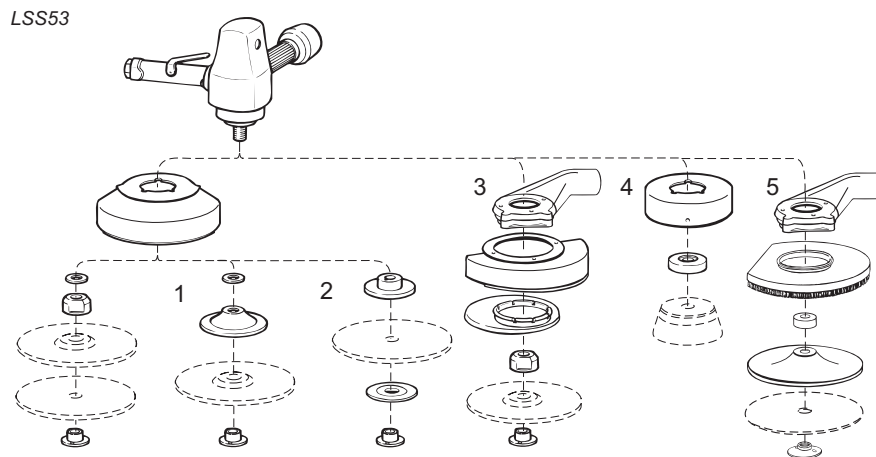

	LSS53	LSS64	See ill.
Accessory for depressed center wheel Includes: Rear and outer flange, nut and pin wrench	4170 0219 87	4170 0219 87	1
Accessory for cut off wheel Includes: Rear and outer flange, nut and pin wrench	4170 1133 87	-	2
Accessory for cup wheel 125 mm Includes: Wheel guard and flange	4170 0664 80	-	4
Accessory for cup wheel 150 mm Includes: Wheel guard and flange	-	4170 0652 80	4
Spot suction kit for fibre disc 180 mm	3780 4011 00	-	5

Productivity Kits

Model	Air inlet BSP	Max air flow	Hose, 5 m	Coupling	Lubrication	Ordering No.
MIDI Optimizer F/RD EQ10-R13-W, incl. whipose	3/8	23 l/s	Rubair 13 mm	ErgoQIC 10	Yes	8202 0850 14
MIDI Optimizer F/RD EQ10-R13-W, incl. whipose	-	23 l/s	Rubair 13 mm	ErgoQIC 10	Yes	8202 0850 15
MIDI Optimizer F/RD EQ10-T13	3/8	35 l/s	Turbo 13 mm	ErgoQIC 10	Yes	8202 0850 17
MIDI Optimizer F/R EQ10-T13	1/2	35 l/s	Turbo 13 mm	ErgoQIC 10	No	8202 0850 04
MIDI Optimizer F/RD EQ10-T13	1/2	35 l/s	Turbo 13 mm	ErgoQIC 10	Yes	8202 0850 13
MIDI Optimizer F/RD EQ10-T16	1/2	40 l/s	Turbo 16 mm	ErgoQIC 10	Yes	8202 0850 12
MAXI F/R C-T16	1/2	60 l/s	Turbo 16 mm	Claw	No	8202 0850 05



Service Kits

LSS53	4081 0132 90
LSS64	4081 0133 90
LSS84	4081 0136 90

Surface sanding jobs with coarse grit fiber discs on stiff pads or with wire brushes, require power. The Atlas Copco LSS series are reliable workhorses with lots of power that will be at your service for a long time. The rigid design with a vertically standing air motor and nodular cast iron cylinder gives impressively long service life and durability.

- LSS series is a good choice in applications where accessibility is of less importance.
- LSS53 is equipped with a unique silencer that reduces the sound peaks created at start and shut-off.



LSS53

Model	Max free speed r/min	Rec. pad size dia mm	Spindle thread and length	Max output		Weight		Height over spindle mm	Air consumption at				Rec. hose size		Air inlet thread BSP	Ordering No.
									max output		free speed					
									kW	hp	kg	lb				
LSS53 S060	6000	180	UNC 5/8 x 30	1.2	1.6	2.3	5.1	180	24.0	51.0	7.0	15.0	13	1/2	1/2	8423 2530 23
LSS53 S060-M14	6000	180	M14 x 31	1.2	1.6	2.3	5.1	180	24.0	51.0	7.0	15.0	13	1/2	1/2	8423 2530 27

Optional Accessories

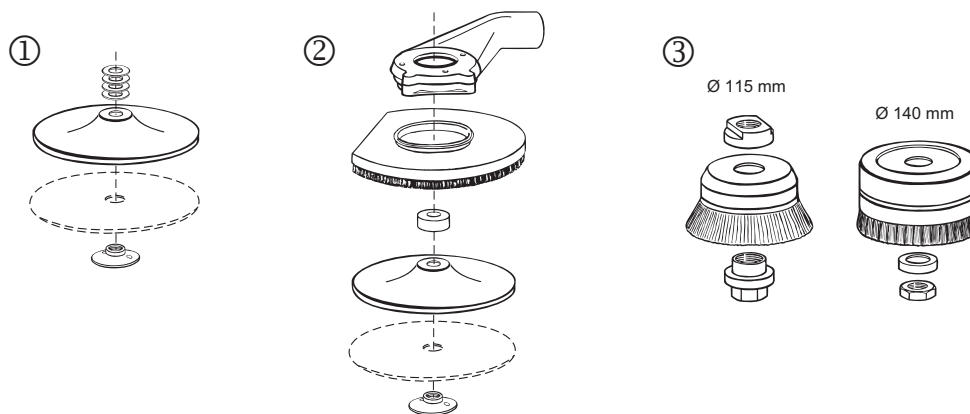

	Soft	Medium	Stiff	See illustration
Backing set				
Standard type Ø 125 mm - 5/8"	4170 0768 80	-	-	1
Standard type Ø 180 mm - 5/8"	4170 0756 80	-	4170 0757 80	1
Heavy duty type - Ø 180 mm - 5/8"	4170 0660 81 ^a	4170 0660 82 ^a	4170 0660 83 ^a	
Backing set with cooling ribs				
Ø 125 mm - 5/8" and M14	-	4150 1962 80	-	-
Ø 180 mm - 5/8" and M14	-	4150 1962 81	4150 1962 83	-
	LSS53	LSS64		See illustration
Spot suction kit for fiber disc				
Ø 180 mm	3780 4011 00 ^b	-	-	2
Wire brushes				
Wire brush 115 mm	4170 0491 00	-	-	3
Attachment set for wire brush	4170 0459 81	4170 0550 80	-	3

^a = Includes washers, rubber hub, back-up pad, nut, wrench.

^b = Includes flow chamber, cap, washers, backingpad, nut.

Productivity Kits

Model	Air inlet BSP	Max air flow	Hose, 5 m	Coupling	Lubrication	Ordering No.
MIDI Optimizer F/RD EQ10-R13-W, incl. whiphose	3/8	23 l/s	Rubair 13 mm	ErgoQIC 10	Yes	8202 0850 14
MIDI Optimizer F/RD EQ10-R13-W, incl. whiphose	-	23 l/s	Rubair 13 mm	ErgoQIC 10	Yes	8202 0850 15
MIDI Optimizer F/RD EQ10-T13	3/8	35 l/s	Turbo 13 mm	ErgoQIC 10	Yes	8202 0850 17
MIDI Optimizer F/R EQ10-T13	1/2	35 l/s	Turbo 13 mm	ErgoQIC 10	No	8202 0850 04
MIDI Optimizer F/RD EQ10-T13	1/2	35 l/s	Turbo 13 mm	ErgoQIC 10	Yes	8202 0850 13
MIDI Optimizer F/RD EQ10-T16	1/2	40 l/s	Turbo 16 mm	ErgoQIC 10	Yes	8202 0850 12
MAXI F/R C-T16	1/2	60 l/s	Turbo 16 mm	Claw	No	8202 0850 05



Service Kits

LSS53	4081 0132 90
LSS64	4081 0133 90

Angle Grinders

For Depressed Center and Cut-off Wheels

No matter which of our vane grinders you choose you will get durable tools with high power and low weight. In addition, vibrations and noise are on a low level.

- LSV19** – For work in cramped spaces, the LSV19 is small yet powerful, and lubrication free.
 Features: Speed governor, sealed angle head, thermally insulated handle and lubrication-free air motor.
- LSV28** – Small, yet powerful giving 0.75 kW.
 Features: Speed governor, sealed angle head, thermally insulated handle and lubrication-free air motor (LSV28 S060-18 model).
- LSV39** – If you are looking for the most powerful one-hand angle grinder on the market, then you have found it – up to 1.8 kW.
 Features: Speed governor, sealed angle head, lubrication-free air motor, lockable spindle and thermally insulated handle. The auto balancer reduces the vibrations by up to 50%.
- LSV48** – Our most powerful angle vane grinder with 1.9 kW for ultimate productivity.
 Features: Speed governor, sealed angle head, lubrication-free air motor, lockable spindle and thermally insulated handle. The autobalancer reduces the vibrations by up to 50%.



LSV28



LSV39



LSV19



LSV48

Model	Max free speed r/min	For wheel dia DxTxH ^a mm	Spindle thread and length	Max output		Weight		Height over spindle mm	Air consumption at				Rec. hose size		Air inlet thread BSP	Ordering No.
				kW	hp	kg	lb		max output l/s	free speed cfm	l/s	cfm	mm	in		
LSV19 S170-08	17000	80x7x10	UNF 3/8"x17	0.45	0.60	0.7	1.6	71	11.2	23.0	6.6	14.0	10	3/8	1/4	8423 0111 40
LSV28 ST12-10	12000	100x7x16	UNF 3/8"x17	0.75	1.00	1.7	3.7	75	17.4	36.9	7.5	15.9	10	3/8	3/8	8423 0125 14
LSV28 ST13-10E	13000	100x7x9.5	UNF 3/8"x17	0.75	1.00	1.5	3.3	70	21.5	45.0	14.5	30.0	10	3/8	3/8	8423 0125 29
LSV28 ST12-12	12000	115x7x22	UNF 3/8"x17	0.75	1.00	1.7	3.7	75	17.4	36.9	7.5	15.9	10	3/8	3/8	8423 0125 16
LSV28 ST12-13	12000	125x7x22	UNF 3/8"x17	0.75	1.00	1.7	3.7	75	17.4	36.9	7.5	15.9	10	3/8	3/8	8423 0125 17
LSV28 S060-18	6000	180 ^b	UNC 5/8"x32	0.73	0.98	2.5	5.4	87	16.0	33.9	7.3	15.5	10	3/8	3/8	8423 0135 53
LSV39 SA12-125	12000	125x7x22	M14x21	1.80	2.40	1.8	4.0	96	29.8	63.0	17.6	37.0	13	1/2	3/8	8423 0133 01
LSV48 SA085-18	8500	180x7x22	M14x9	1.9	2.5	2.7	5.9	88	36.0	76.0	17.0	36.0	16	5/8	1/2	8423 0132 06
LSV48 SA066-23	6600	230x7x22	UNC 5/8"x10	1.9	2.5	2.9	6.4	88	36.0	76.0	17.0	36.0	16	5/8	1/2	8423 0132 08
For wire brush																
LSV39 SA085-125	8500	125x7x22	M14x21	1.80	2.40	1.8	4.0	96	29.5	61.1	16.3	33.7	13	1/2	3/8	8423 0133 09

^a DxTxH = Diameter x Thickness x Hole.

^b Specially for flexible depressed center wheel.

SA = Autobalancer.

With wheel guard for wheel diam. –08 = Ø 80 mm

–10 = Ø 100 mm

–12 = Ø 115 mm

–125 = Ø 125 mm

–13 = Ø 125 mm

–18 = Ø 180 mm

–23 = Ø 230 mm



Service Kits

LSV19	4081 0486 90
LSV28	4081 0317 90
LSV39	4081 0537 90
LSV48	4081 0312 90

Accessories Included

LSV19

Wheel guard 80 mm
 Flanges 4150 1158 80
 Air hose nipple, clamp
 Wrenches
 Exhaust hose set

LSV28

Wheel guard
 Flanges 4150 1160 80
 Support handle 4150 1521 80
 Air hose, air hose nipple, clamp
 Wrenches
 Exhaust hose set

LSV39

Adjustable wheel guard
 Wheel attachment flanges
 Wrenches for flanges
 Spindle lock
 Soft grip support handle
 Exhaust hose
 Autobalancer
 Whip hose Turbo 13 with ErgoNIP 10

LSV48

Wheel guard
 Flange nut 4150 1160 02
 Support handle 4175 0868 82

Optional Accessories

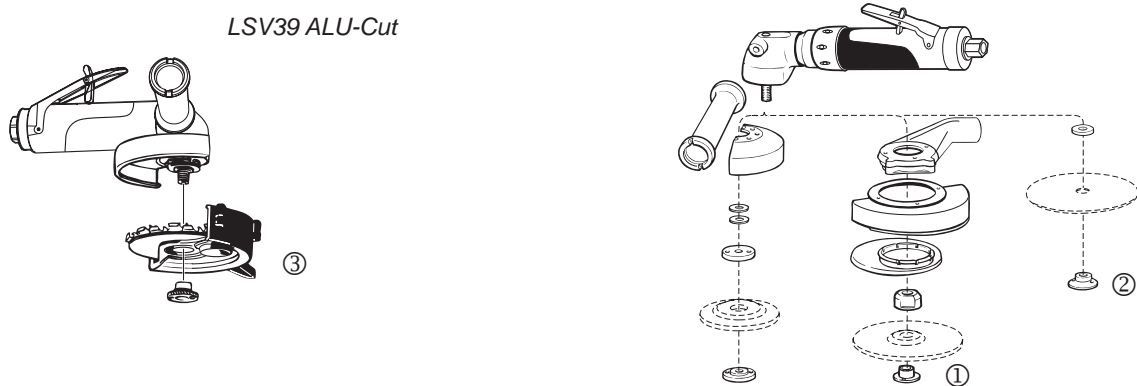

	LSV28	LSV39	LSV48	See illustration
Spot suction kit for depressed center wheel Ø 125 mm	3780 4008 70	3780 4008 73	-	1
Spot suction for diamond cutting blade Ø 125 mm (Cutting depth 30 mm)	-	3780 4008 74	-	-
Ø 180 mm (Cutting depth 50 mm)	-	-	3780 4093 42	-
Diamond cutting blade Ø 75 mm	3780 5073 00	-	-	-
Ø 100 mm	3780 5074 00	-	-	-
Ø 125 mm	-	3780 5074 61	-	-
Ø 180 mm	-	-	3780 5074 62	-
Alu-Cut Alu-Cut guard kit	-	4112 1166 90	-	3
Carbide tipped cutter Ø 125 mm, t=2 mm	-	4112 1164 00 ^a	-	-
Carbide tipped cutter Ø 125 mm, t=4 mm	-	4112 1162 00 ^b	-	-
Adapter for fitting flexible depressed center wheel (for LSV28 S060-18)	4170 0759 00	-	-	2
Quick flange nut, M14 Fixtec nut	-	4150 1929 00	4150 1929 00	-
Add on spot suction Ø 115-125 mm	3780 4032 14	3780 4032 14	3780 4032 14	-
Ø 180-230 mm	-	-	3780 4032 12	-

^a For cutting applications in aluminum.

^b For milling applications in aluminum.

Productivity Kits

Model	Air inlet BSP	Max air flow	Hose, 5 m	Coupling	Lubrication	Ordering No.
MIDI Optimizer F/RD EQ10-R13-W, incl. whiphose	3/8	23 l/s	Rubair 13 mm	ErgoQIC 10	Yes	8202 0850 14
MIDI Optimizer F/RD EQ10-R13-W, incl. whiphose	-	23 l/s	Rubair 13 mm	ErgoQIC 10	Yes	8202 0850 15
MIDI Optimizer F/RD EQ10-T13	3/8	35 l/s	Turbo 13 mm	ErgoQIC 10	Yes	8202 0850 17
MIDI Optimizer F/R EQ10-T13	1/2	35 l/s	Turbo 13 mm	ErgoQIC 10	No	8202 0850 04
MIDI Optimizer F/RD EQ10-T13	1/2	35 l/s	Turbo 13 mm	ErgoQIC 10	Yes	8202 0850 13
MIDI Optimizer F/RD EQ10-T16	1/2	40 l/s	Turbo 16 mm	ErgoQIC 10	Yes	8202 0850 12

- LSV12 series sander** – For finer work where less power and more control are needed. Available with collet or threaded spindle.
 Features: Speed governor, high quality gears and lever with feathering characteristics.
- LSV28 series sander** – The 28 series comes in various speeds and in a wet sanding version. Wet sanders have central water supply (water feed through the angle head) for optimal water distribution on the work surface.
 Features: Speed governor, sealed angle head, LF models have lubrication-free air motor.
- LSV39 series sander** – Powerful one hand sander for medium rough to rough sanding.
 Features: Speed governor, sealed angle head, lubrication-free air motor and lockable spindle.
- LSV48 series sander** – Our most powerful angle vane sander with 1.9 kW for ultimate productivity.
 Features: Speed governor, sealed angle head, lubrication-free air motor, autobalancer and lockable spindle.



Model	Max free speed r/min	Rec. pad size max dia mm	Spindle thread and length	Max output		Weight kg	Length mm	Height over spindle mm	Air consumption at				Rec. hose size mm in	Air inlet thread BSP	Ordering No.		
				kW	hp				max output		free speed						
With collet																	
LSV12 S200-1	20000	50	— ^a	0.29	0.39	0.5	1.2	166	76	9.5	20.1	6.4	13.6	8	5/16	1/4	8423 1124 06
LSV12 S120-1	12000	75	— ^a	0.24	0.33	0.5	1.2	166	76	8.3	17.6	3.0	6.4	8	5/16	1/4	8423 1124 05
LSV19 S200-1	20000	50	— ^a	0.46	0.62	0.6	1.3	185	79	11.3	23.9	7.5	15.9	10	3/8	1/4	8423 0111 41
LSV19 S120-1	12000	75	— ^a	0.46	0.62	0.6	1.3	185	79	11.3	23.9	7.5	15.9	10	3/8	1/4	8423 0111 43
LSV19 S080-1	8000	75	— ^a	0.37	0.5	0.6	1.3	185	79	11.3	23.9	6.5	13.8	10	3/8	1/4	8423 0111 46
With threaded spindle																	
LSV12 S200	20000	50	UNC 1/4"x8	0.29	0.39	0.5	1.2	166	58	8.3	17.6	3.0	6.4	8	5/16	1/4	8423 1124 08
LSV12 S120	12000	75	UNC 1/4"x8	0.24	0.33	0.5	1.2	166	58	8.3	17.6	3.0	6.4	8	5/16	1/4	8423 1124 07
LSV19 S200	20000	50	UNC 1/4"x8	0.46	0.62	0.6	1.3	185	58	11.3	23.9	7.5	15.9	10	3/8	1/4	8423 0111 42
LSV19 S120	12000	75	UNC 1/4"x8	0.46	0.62	0.6	1.3	185	58	11.3	23.9	7.5	15.9	10	3/8	1/4	8423 0111 44
LSV19 S080	8000	75	UNC 1/4"x8	0.37	0.5	0.6	1.3	185	58	11.3	23.9	6.5	13.8	10	3/8	1/4	8423 0111 45
Rotary sanders. Dry sanding																	
LSV28 S060	6000	180	UNC 5/8"x32	0.73	0.98	1.5	3.2	265	87	16.0	33.9	7.3	15.5	10	3/8	3/8	8423 0125 30
LSV28 S060-M14	6000	180	M14x16	0.73	0.98	1.5	3.2	265	87	16.0	33.9	7.3	15.5	10	3/8	3/8	8423 0125 64
LSV28 S040	4000	180	UNC 5/8"x32	0.62	0.83	1.5	3.2	265	87	15.0	31.8	4.0	8.5	10	3/8	3/8	8423 0126 22
LSV28 ST034	3400	180	UNC 5/8"x32	0.71	0.95	1.7	3.7	289	87	18.0	38.2	7.7	16.3	10	3/8	3/8	8423 0135 80
LSV28 S021	2100	180	UNC 5/8"x32	0.68	0.91	1.9	4.1	289	87	16.0	33.9	5.6	11.9	10	3/8	3/8	8423 0125 19
LSV28 S021-M14	2100	180	M14x16	0.68	0.91	1.9	4.1	289	87	16.0	33.9	5.6	11.9	10	3/8	3/8	8423 0125 72
Wet sanding																	
LSV28 S040-01-M14	4000	180	M14x16	0.62	0.83	1.5	3.2	268	87	15.0	31.8	5.0	10.6	10	3/8	3/8	8423 0125 12
LSV28 ST008-01 LF	800	200	UNC 5/8"x32	0.68	0.91	2.0	4.3	307	87	16.0	33.9	5.6	11.9	10	3/8	3/8	8423 0125 51
Lubrication-free. Dry sanding																	
LSV28 ST013-M14 LF	1300	180	M14x16	0.68	0.91	1.7	3.7	289	87	20.0	42.4	9.0	19.1	10	3/8	3/8	8423 0125 28
LSV28 ST013 LF	1300	180	UNC 5/8"x32	0.68	0.91	1.7	3.7	289	87	20.0	42.4	9.0	19.1	10	3/8	3/8	8423 0126 26
LSV39 S085-5/8	8500	180	5/8" x 28	1.80	2.40	1.6	3.5	231	96	29.5	61.1	16.3	33.7	13	1/2	3/8	8423 0133 03
LSV39 S085-M14	8500	180	M14 x 28	1.80	2.40	1.6	3.5	231	96	29.5	61.1	16.3	33.7	13	1/2	3/8	8423 0133 04
LSV39 S066-5/8	6600	180	5/8" x 28	1.60	2.10	1.6	3.5	231	96	26.2	54.3	11.6	24.0	13	1/2	3/8	8423 0133 05
LSV39 S066-M14	6600	180	M14 x 28	1.60	2.10	1.6	3.5	231	96	26.2	54.3	11.6	24.0	13	1/2	3/8	8423 0133 06
LSV39 S120-5/8	12000	125	5/8" x 28	1.80	2.40	1.6	3.5	231	96	29.5	61.1	16.3	33.7	13	1/2	3/8	8423 0133 07
LSV48 SA085	8500	180	UNC 5/8"x21	1.9	2.5	2.3	5.1	316	78	36.0	76.0	17.0	36.0	16	5/8	1/2	8423 0132 02
LSV48 SA085-M14	8500	180	M14x18	1.9	2.5	2.3	5.1	316	78	36.0	76.0	17.0	36.0	16	5/8	1/2	8423 0132 03
LSV48 SA066	6600	180	UNC 5/8"x21	1.9	2.5	2.3	5.1	316	78	36.0	76.0	17.0	36.0	16	5/8	1/2	8423 0132 00

^a Ø 6 mm collet.

-ST = Models with planetary gears.

-SA = Autobalancer.

Accessories Included

Air hose nipple	Exhaust hose (LSV19/28/39)	Wrenches
Clamp	Support handle (LSV28/39/48)	

Optional Accessories

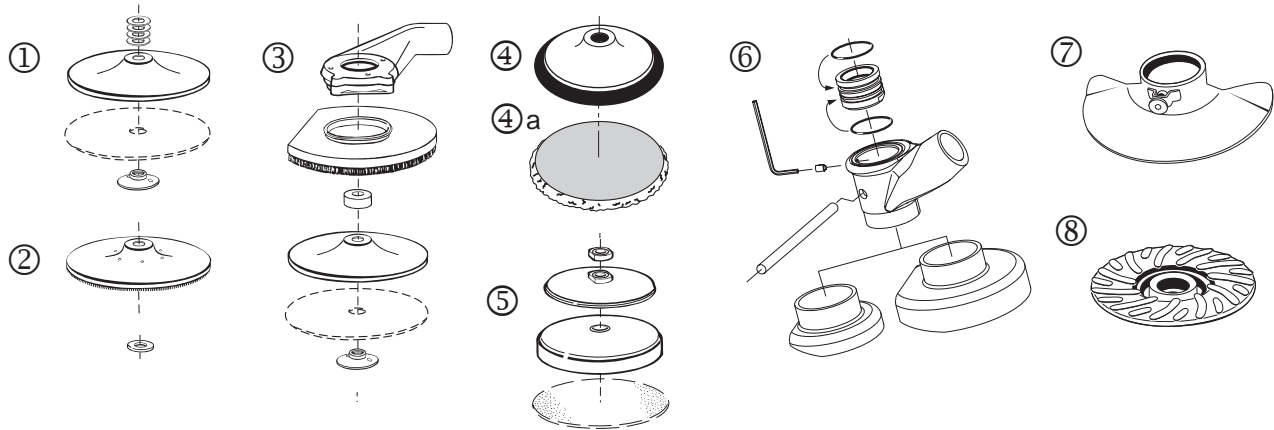

	LSV12	LSV19	LSV28	LSV39	LSV48	See ill.
Backing set, standard type						
Ø 125 mm - 5/8" - soft	-	-	4170 0768 80	4170 0768 80	4170 0768 80	1
Ø 180 mm - 5/8" - soft	-	-	4170 0756 80	4170 0756 80	4170 0756 80	1
Ø 180 mm - 5/8" - stiff	-	-	4170 0757 80	4170 0757 80	4170 0757 80	1
Backing set with cooling ribs						
Ø 125 mm - 5/8" and M14, medium	-	-	4150 1962 80	4150 1962 80	4150 1962 80	2
Ø 180 mm - 5/8" and M14, stiff	-	-	-	4150 1962 83	4150 1962 83	2
Ø 180 mm - 5/8" and M14, medium	-	-	4150 1962 81	4150 1962 81	4150 1962 81	2
Backing set, heavy duty type						
Ø 120 mm - M14	-	-	-	4175 0883 93	4175 0883 93	8
Ø 162 mm - M14	-	-	-	4175 0883 91	4175 0883 91	8
Ø 120 mm - 5/8"	-	-	-	4175 0883 92	4175 0883 92	8
Ø 162 mm - 5/8"	-	-	-	4175 0883 90	4175 0883 90	8
Backing set for polishing - velcro						
Ø 150 mm - 5/8" (max 2500 rpm)	-	-	4112 6092 15	-	-	4
Ø 150 mm - Lambs wool bonnet	-	-	4112 6093 15	-	-	4a
Backing set for wet sanding						
Ø 180 mm - 5/8" - foam rubber (max 2500 rpm)	-	-	4170 0428 83	-	-	5
Spot suction kit for fiber disc						
Ø 125 mm	-	-	3780 4007 80 ^a	3780 4008 85	-	3
Ø 180 mm	-	-	3780 4007 90 ^{b/}	3780 4008 84	3780 4093 40	3
			3780 4031 60 ^c			3
Ø 50 - 75 mm	3780 4092 64 ^d	3780 4092 62 ^{d/}	-	-	-	6
		3780 4092 65 ^e				6
Hand shield for 125-180 mm	-	-	-	4150 1936 80	-	7
Hand shield large, for 125-180 mm	-	-	-	4150 1941 80	-	7

^a = Suits LSV28 S060 ^c = Suits LSV28 S021 ^e = For model with threaded spindle
^b = Suits LSV28 S040/060 ^d = For model with collet

Productivity Kits

Model	Air inlet BSP	Max air flow	Hose, 5 m	Coupling	Lubrication	Ordering No.
MIDI Optimizer F/RD EQ10-R13-W, incl. whiphose	3/8	23 l/s	Rubair 13 mm	ErgoQIC 10	Yes	8202 0850 14
MIDI Optimizer F/RD EQ10-R13-W, incl. whiphose	-	23 l/s	Rubair 13 mm	ErgoQIC 10	Yes	8202 0850 15
MIDI Optimizer F/RD EQ10-T13	3/8	35 l/s	Turbo 13 mm	ErgoQIC 10	Yes	8202 0850 17
MIDI Optimizer F/R EQ10-T13	1/2	35 l/s	Turbo 13 mm	ErgoQIC 10	No	8202 0850 04
MIDI Optimizer F/RD EQ10-T13	1/2	35 l/s	Turbo 13 mm	ErgoQIC 10	Yes	8202 0850 13
MIDI Optimizer F/RD EQ10-T16	1/2	40 l/s	Turbo 16 mm	ErgoQIC 10	Yes	8202 0850 12



Service Kits

LSV19	4081 0486 90	LSV39	4081 0537 90
LSV28	4081 0317 90	LSV48	4081 0312 90

Belt Sanders

For Sanding and Polishing

LMB27/LMB35 are suitable for precision sanding where access is difficult with conventional sanders.

The head rotation provides a versatile solution for many applications.



LMB35

LMB27

Model	Max output		Belt speed m/min	Belt dimension mm	Weight		Air consumption at free speed		Rec. hose size		Air inlet thread BSP in	Ordering No.
	kW	hp			kg	lb	l/s	cfm	mm	in		
LMB27 S014	0.275	0.37	1400	13X305	0.9	2	10	21.2	10	3/8	1/4	8423 0305 10
LMB35 S015	0.350	0.41	1500	19X520	1	2.2	11	23.3	10	3/8	1/4	8423 0305 20

Accessories

CONTACT ARM SANDING BELTS / CONTACT ARM FELT BELTS

Model	Ordering No.
Contact arm sanding belts	
LMB27	
13 x 305 mm (1/2" x 12")(std arm)	4112 3007 88
3 and 6 x 305 mm (1/8" and 1/4" x 12")	4112 3007 78
LMB35	
19 x 520 mm (3/4" x 20-1/2")(std arm)	4112 3008 83
19 x 460 mm (3/4" x 18")	4112 3008 81
Contact arm felt belts	
LMB27	
13 x 305 mm (1/2" x 12")	4112 3007 79

3M SANDING BELT KIT

	Grit size			
	40+	60+	80+	120+
G2410				
20 pcs, 6 x 305 mm (1/4"x12")	4170 1208 00	4170 1208 02	4170 1208 03	4170 1208 04
20 pcs, 13 x 305 mm (1/2"x12")	4170 1208 05	4170 1208 06	4170 1208 07	4170 1208 08
G2420				
20 pcs, 19 x 520 mm (3/4"x20-1/2")	4170 1208 13	4170 1208 14	4170 1208 15	4170 1208 16

3M SCOTCH-BRITE FELT BELT KIT

	Coars		
	Coars	Medium	Very fine
LMB27			
10 pcs, 13 x 305 mm (1/2"x12")	4170 1210 00	4170 1210 01	4170 1210 02



Service Kits

Model	Ordering No.
Service kit motor	
LMB35	4081 0520 90
LMB27	4081 0501 90
Service kit general	
LMB35	4081 0519 90
LMB27	4081 0502 90
Service kit belt support	
LMB35	4081 0521 90
LMB27	4081 0503 90

Orbital and Random Orbital Sanders

Atlas Copco series of random orbital sanders combines all the important customer and application requirements in a very competitive range of products. Applications like sanding before painting and surface coating, polishing with wax and surface conditioner are all quickly done with the small and easily operated LST20-range of sanders.

All models are lubrication free and have silicone free components. The full range includes standard and dust extraction models, with three different orbit diameters to choose from.



Model	Max free speed r/min	Pad size mm	Orbit dia mm	Max output		Weight		Height over spindle mm	Length mm	Air consumption at free speed		Rec. hose size mm	Air inlet thread BSP	Ordering No.
				kW	hp	kg	lb			l/s	cfm			
Random orbital – Standard														
LST30 H090-11	9000	110	8	0.3	0.4	1.2	2.6	120	255	7.5	16	8	1/4	8423 0361 64
LST30 H090-15	9000	150	8	0.3	0.4	1.2	2.6	120	275	7.5	16	8	1/4	8423 0361 72
LST30 S090-15	9000	150	8	0.3	0.4	1.1	2.4	120	175	7.5	16	8	1/4	8423 0361 98
Self suction^a														
LST31 H090-15	9000	150	8	0.3	0.4	1.4	3.0	120	300	7.5	16	8	1/4	8423 0363 19
Central suction^b														
LST32 H090-15	9000	150	8	0.3	0.4	1.4	3.0	120	300	7.5	16	8	1/4	8423 0362 55
LST32 S090-15	9000	150	8	0.3	0.4	1.3	2.9	120	200	7.5	16	8	1/4	8423 0362 71
Orbital – Standard														
LSO30 S070-3	7000	93x170	5	0.3	0.4	1.6	3.5	125	185	7.5	16	8	1/4	8423 0360 16
LSO30 H070-3	7000	93x170	5	0.3	0.4	1.7	3.7	125	285	7.5	16	8	1/4	8423 0360 24
Central suction^c														
LSO32 H070-3	7000	93x170	5	0.3	0.4	1.8	4.0	125	310	7.5	16	8	1/4	8423 0361 07
Standard model														
LST20 R350	12000	90	5	0.2	0.27	0.85	1.85	95	127	8	17	8	1/4	8423 0361 65
LST20 R550	12000	125	5	0.2	0.27	0.85	1.85	83	127	8	17	8	1/4	8423 0361 69
LST20 R650	12000	150	5	0.2	0.27	0.85	1.85	83	127	8	17	8	1/4	8423 0361 73
LST20 R525	12000	125	2.4	0.2	0.27	0.85	1.85	83	127	8	17	8	1/4	8423 0361 81
LST20 R625	12000	150	2.4	0.2	0.27	0.85	1.85	83	127	8	17	8	1/4	8423 0361 84
Extraction model – self suction														
LST21 R550	12000	125	5	0.2	0.27	0.85	1.85	83	133 ^d	8	17	8	1/4	8423 0361 70
LST21 R650	12000	150	5	0.2	0.27	0.85	1.85	83	133 ^d	8	17	8	1/4	8423 0361 74
Extraction model – central suction^c														
LST22 R550	12000	125	5	0.2	0.27	0.85	1.85	83	133 ^d	8	17	8	1/4	8423 0361 71
LST22 R650	12000	150	5	0.2	0.27	0.85	1.85	83	133 ^d	8	17	8	1/4	8423 0361 75

^a Includes dust collecting bag.

^b Required air flow 150 m³/h or 88 cfm.

^c Required air flow 60 m³/h or 35 cfm.

^d 186 mm (7.3") suction hose connector included.

H = With handle.

S = Without handle.

-9 Velcro pad, 9 holes.

Accessories Included

LSO

- Base pad
- Perforating plate
- Hose nipple for 8 mm hose

LST20/21/22

- Velcro pad
- U-wrench for pad change
- Air hose nipple
- Dust hose and bag (LST21)
- Large and small grip cover

LST30/31/32

- Velcro pad
- Bar for changing pad
- Hose nipple for 8 mm hose
- LST31 incl dust collection kit

LSO

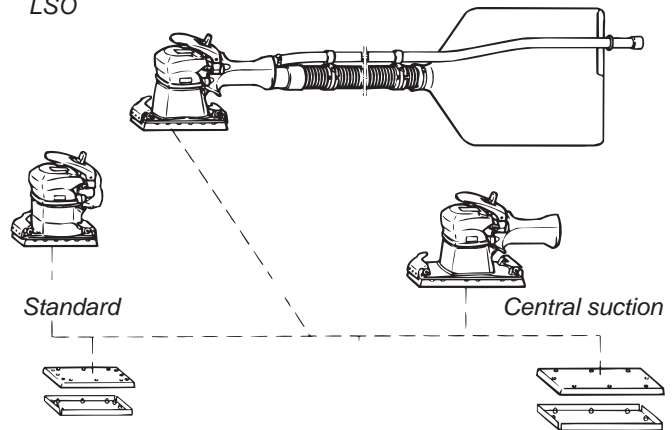

Optional Accessories

LSO

For LSO	Ordering No.
Base pad, vinyl for F-type	4112 0787 01

LST20/21/22, PAD FOR SELF STICK PAPER

	Ordering No.		
	Dia 89 mm	Dia 125 mm	Dia 150 mm
For LST20	4112 1231 00	4112 1233 00	4112 1235 00
For LST21/22		4112 1232 00	4112 1234 00

LST20/21/22, PAD FOR VELCRO BACK PAPER

	Ordering No.		
	Dia 89 mm	Dia 125 mm	Dia 150 mm
For LST 20	4112 1218 00	4112 1216 00	4112 1214 00
For LST 21/22	-	4112 1217 00	4112 1215 00

LST30/31/32

	Ordering No.
Pad velcro, Ø 150 mm	4112 0795 01 ^a
Pad velcro, Ø 110 mm	4112 0792 02 ^b

^aLST30-15 ^bLST30/32-11



Service Kits

LST20/21/22	4112 1300 90
LST30/31/32	4081 0131 90

LST

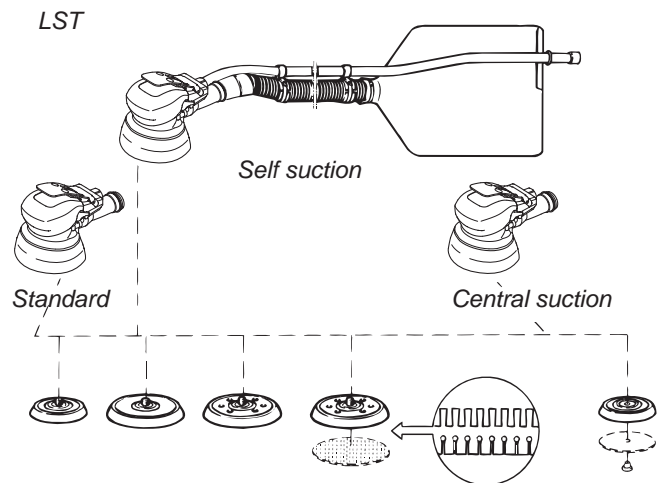

HOLE PATTERN DIMENSIONS FOR SANDING PAPER, DUST EXTRACTION MODELS

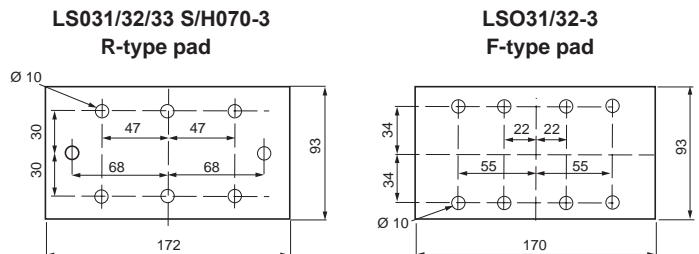

LST20/21/22, 30/31/32

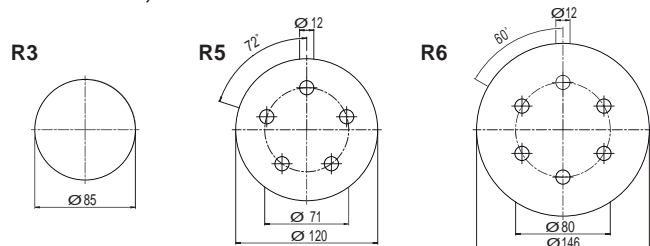

The fact that dust can represent a hazard in the working environment is well documented.

Dust particles from certain materials are dangerous to health. Even inert dust particles that cause no permanent damage can still be retained in the body and make breathing more difficult.

Efficient dust control can make a significant contribution to efficiency and productivity in industrial operations. It is already a requirement in countries with strict health and safety regulations.

Efficient dust control will:

- Reduce the health risk for operators exposed to potentially dangerous particles.
- Give a more favourable working environment which will encourage greater efficiency and effort from those who operate industrial tools.

The most efficient method of dust collection is extraction at the point of dust creation, i.e. on the tool itself. This not only ensures very efficient extraction but also allows a relatively low power vacuum source to be used.

Atlas Copco spot suction kits provide



LSV 39

an extraction hood fixed to the tool. It is fitted with a plastic or brush edge to trap heavier particles as well as the small ones. The following pages show a number of applications and the necessary dust extraction kits with their contents.

MODELS PREPARED FOR USE WITH SPOT SUCTION KIT

Model	Max free speed r/min	Max output		Weight		Height over spindle		Air consumption at				Spindle thread	Air inlet thread BSP	Ordering No.
		kW	hp	kg	lb	mm	in	max power l/s	cfm	free speed l/s	cfm			
LSV48 SA085	8500	1.9	2.5	2.3	5.1	78	3	36	76	17	36	UNC 5/8x21	1/2	8423 0132 02
LSV48 SA066	6600	1.9	2.5	2.3	5.1	78	3	36	76	17	36	UNC 5/8x21	1/2	8423 0132 00
LSV39 S085-5/8	8500	1.80	2.4	1.6	3.5	96	3.8	29.5	61.1	16.3	33.7	5/8x28	3/8	8423 0133 03
LSV39 S085-M14	8500	1.80	2.4	1.6	3.5	96	3.8	29.5	61.1	16.3	33.7	M14x28	3/8	8423 0133 04
LSV39 S066-5/8	6600	1.60	2.1	1.6	3.5	96	3.8	26.2	54.3	11.6	24	5/8x28	3/8	8423 0133 05
LSV39 S066-M14	6600	1.60	2.1	1.6	3.5	96	3.8	26.2	54.3	11.6	24	M14x28	3/8	8423 0133 06
LSV39 S120-5/8	12000	1.80	2.4	1.6	3.5	96	3.8	29.5	61.1	16.3	33.7	5/8x28	3/8	8423 0133 07

Spot suction kits are not included and must be ordered separately, see below.

SPOT SUCTION KITS FOR GTG25, LSV48 AND LSV39

Model	Ordering No.	Application			
		Sanding Fiber disc dia, mm		Cutting GRP cutting with cutter disc dia, mm	
		125	180	125	180
GTG25 S085	8423 2525 03		3780 4090 27		
GTG25 S085-M14	8423 2525 04		3780 4090 27		
LSV48 SA085	8423 0132 02		3780 4093 40		3780 4093 42
LSV48 SA066	8423 0132 00		3780 4093 40		3780 4093 42
LSV39 S085-5/8	8423 0133 03		3780 4008 84		
LSV39 S085-M14	8423 0133 04		3780 4008 84		
LSV39 S066-5/8	8423 0133 05		3780 4008 84		
LSV39 S066-M14	8423 0133 06		3780 4008 84		
LSV39 S120-5/8	8423 0133 07	3780 4008 85		3780 4008 74	
Optional accessory Cutting disc				3780 5074 61	3780 5074 62

KIT FOR BURR AND DRUM

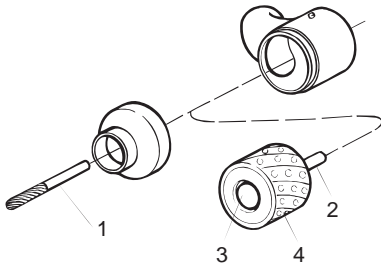

KIT FOR SANDING PAD

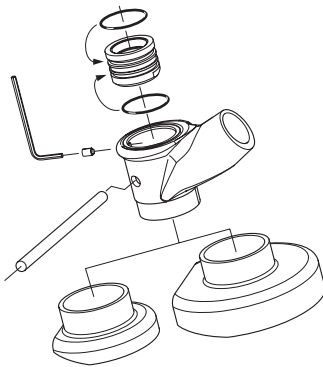

Add on spot suction

KIT FOR DEPRESSED CENTER AND CUT OFF WHEELS

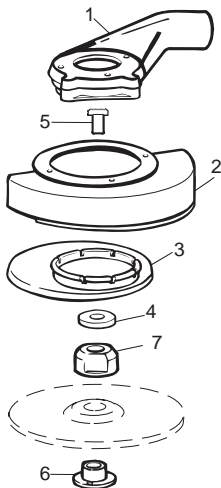

SPOT SUCTION KITS FOR DIE GRINDERS

Suction requirement: 125 m³/h (LSV12), 125 m³/h (LSF19), 200 m³/h (LSF28)

		Ordering No.
LSV12	KIT for sanding pad dia 50 and 75 mm	3780 4092 64
LSF19 S	KIT for burr	3780 3015 22
	Optional 1 Diamond burr 6 mm	3780 5013 70
LSF19 S	KIT for drum	3780 4011 61
	Includes 2 Shaft dia 6 mm	3780 5090 30
	3 Locking screw	3780 5090 60
	Optional 4 Diamond drum 27 mm	3780 5033 00
LSV19 S with collet	KIT for sanding, pad Ø 50 and Ø 75 mm	3780 4092 62
LSV19 S with threaded spindle	KIT for sanding, pad Ø 50 and Ø 75 mm	3780 4092 65
LSF28 S	KIT for burr	3780 4007 42
	Optional 1 Diamond burr 6 mm	3780 5013 70
LSF28 S	KIT for drum	3780 4011 73
	Includes 2 Shaft dia 8 mm	3780 5091 00
	3 Locking nut	3780 5092 00
	Optional 4 Diamond drum, Ø 52 mm	3780 5035 00

ADD ON SPOT SUCTION

	Ordering No.
Ø 125 mm	3780 4032 14
Ø 180-230 mm	3780 4032 12

SPOT SUCTION KITS FOR DEPRESSED CENTER WHEELS

Suction requirement: 250 m³/h

		Ordering No.
LSV28 ST12 125 mm wheel	KIT	3780 4008 70
	Includes 5 Adapter UNF 3/8" UNC 5/8"	4021 0457 00
	6 Nut 5/8"	3780 2722 00

VACUUM HOSE, 1.8 M

Hose	Ordering No.
Ø 25 mm for 125 m ³ /h suction requirement	3780 2724 20
Ø 32 mm for 200 m ³ /h suction requirement	3780 2724 31
Ø 38 mm for 250 m ³ /h suction requirement	3780 2724 40

BRUSH FOR SUCTION CAP

	Ordering No.
Separate brush for cap Ø 125 mm (20 mm high)	3780 2678 00
Separate brush for cap Ø 180 mm (20 mm high)	3780 2677 50
Separate brush for cap Ø 180 mm (30 mm high)	3780 2677 30

LSV28/39/48/GTG40

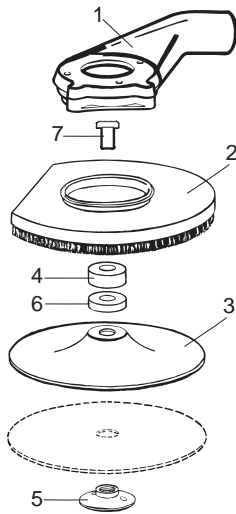

SPOT SUCTION KITS FOR SANDING WITH FIBER DISC. SANDERS WITH UNC 5/8" SPINDLE.

Suction requirement: 250 m ³ /h		Ordering No.
LSV28 S040/S060 125 mm	KIT	3780 4007 80
Includes	2 Suction cap 125 mm with brush	3780 2650 20
	3 Backing pad 125 mm	3780 2710 30
	4 Distance washer 12 mm	3780 2721 60
	5 Nut 5/8"	3780 2722 00
LSV28 ST12-13 125 mm	KIT	3780 4008 60
Includes	2 Suction cap 125 mm with brush	3780 2650 20
	3 Backing pad 125 mm	3780 2710 30
	6 Distance washer 9 mm	3780 2721 50
	7 Adapter UNF 3/8" UNC 5/8"	4021 0457 00
	5 Nut 5/8"	3780 2722 00
LSV28 S040/S060 180 mm	KIT	3780 4007 90
Includes	2 Suction cap 180 mm with brush	3780 2675 00
	3 Backing pad 180 mm	3780 2710 60
	6 Distance washer 9 mm	3780 2721 50
	5 Nut 5/8"	3780 2726 70
LSV28 S021 180 mm	KIT	3780 4031 60
Includes	2 Suction cap 180 mm with brush	3780 2675 00
	3 Backing pad	3780 2710 60
	6 Distance washer 12 mm	3780 2721 60
	5 Nut 5/8"	3780 2726 70
LSV39 S066/S085 180 mm	KIT	3780 4008 84
Includes	2 Suction cap 180 mm with brush	3780 2675 00
	3 Backing pad 180 mm	3780 2710 60
	5 Nut 5/8"	3780 2726 70
	6 Distance washer 9 mm	3780 2721 50
LSV39 S120 125 mm	KIT	3780 4008 85
Includes	2 Suction cap 125 mm with brush	3780 2650 20
	3 Backing pad 125 mm	3780 2710 30
	5 Nut 5/8"	3780 2726 70
	6 Distance washer 9 mm	3780 2721 50
LSV48 SA066/SA085 180 mm	KIT	3780 4093 40
Includes	2 Suction cap 180 mm with brush	3780 2675 00
	3 Backing pad 180 mm	3780 2710 60
	4 Distance washer 9 mm	3780 2721 50
	5 Nut 5/8"	3780 2726 70
LSS53 S060 180 mm	KIT	3780 4011 00
Includes	2 Suction cap 180 mm with brush	3780 2675 00
	3 Backing pad 180 mm	3780 2710 60
	4 Distance washer 12 mm	3780 2721 60
	5 Nut 5/8"	3780 2726 70
GTG40 S060 180 mm	KIT	3780 4090 11
Includes	2 Suction cap 180 mm with brush	3780 2675 31
	3 Backing pad 180 mm	3780 2710 60
	4 Distance washer 6 mm	3780 2721 40
	5 Nut 5/8"	3780 2722 00

Pattern fixture cutting of composite in the aerospace industry as well as trimming of composite materials is preferably done with a router. The LSK37 is the only router with dust extraction and support bearing integrated into one unit. The LSK38 is prepared for using other router heads that are available on the market. This gives the LSK excellent performance and ergonomics in most composite applications.

- **Productive** – The speed governor maintains the rotational speed at applied feed force which enables fast and effective cutting and prevents the bit from clogging.
- **Ergonomic** – An integrated dust extraction hood for deportation of hazardous dust, thermally insulated throttle handle, sound dampening exhaust valve and piped-away exhaust air provides the operator with the best working environment.



LSK38



LSK37

Model	Free speed r/min	Collet size	Weight		Power		Air consumption		Rec. hose size		Hose fitting thread BSP	Ordering No.
			kg	lb	kW	hp	l/s	cfm	mm	in		
LSK37 S250-DS1	25000	6 mm	2.8	6.1	0.7	0.95	18	32	13	1/2	3/8	8423 1234 41
LSK37 S250-DS2	25000	1/4"	2.8	6.1	0.7	0.95	18	32	13	1/2	3/8	8423 1234 42
LSK38 S250 Do	25000	1/4"	1.1	2.2	1.3	1.8	28	58	13	1/2	3/8	8423 0700 00
LSK38 S180 Do	18000	1/4"	1.1	2.2	1.3	1.8	28	58	13	1/2	3/8	8423 0700 01

Suction requirement: LSK37: 200 m³/h. **NOTE:** LSK38 delivered without router head.

KIT FOR SANDING WITH FIBER DISC

Circular cutting operations in glass and carbon fiber as well as sheet metal and wood can successfully be performed with a circular cutter.

- **Effective** – LCS10 and LCS38 cut to a depth of 10 and 26 mm respectively.
- LCS38 is suitable for diamond coated blades only.
- **Dust extraction** – Cutting of composite materials generates dust containing particles that are hazardous to health. The dust must be deported in order to prevent the operator from inhaling it.

LCS38 is equipped with a cutter blade guard with integrated dust extraction hood for external vacuum source.

LCS38



LCS10



Model	Free speed r/min	Max output		Max cutting depth mm	Max cutter blade dia mm	Weight		Air consumption at free speed		Rec. hose size		Air inlet thread BSP	Ordering No.
		kW	hp			kg	lb	l/s	cfm	mm	in		
LCS10	3000	0.3	0.4	10	50	1.4	3.1	7.6	16	6.3	1/4	1/4	8424 1161 38
LCS38 S150D ^a	15000	1.3	1.7	26	100	1.7	3.7	28.0	58	13.0	1/2	3/8	8424 1125 06

^a Suction requirement: 200 m³/h.

Accessories Included

LCS38

- Flanges for diamond blade
- Hose nipple for 13 mm air hose
- Exhaust hose

Optional Accessories

CUTTER BLADES

Model	Application	Max thickness of material mm	No. of teeth mm	Dia mm	Hole mm	Ordering No.
LCS10	Steel sheet	1.0	92	50	10	4190 0394 00
	Steel sheet	1.0	62	50	10	4190 0395 00 (std)
	Aluminum	2.5	34	50	10	4190 0396 00
	Wood	10.0	34	50	10	4190 0396 00
LCS38	Glassfibre	18.0	44/60 (Grain)	75	12	3780 5073 00
	Glassfibre	25.0	44/60 (Grain)	100	12	3780 5074 00

Model	Ordering No.
Suction hose set for LCS38 (L= 150 mm, Dia 1 1/4")	3780 2724 31

Productivity Kits

Model	Air inlet BSP	Max air flow	Hose, 5 m	Coupling	Lubrication	Ordering No.
MIDI Optimizer F/RD EQ10-T13	3/8	35 l/s	Turbo 13 mm	ErgoQIC 10	Yes	8202 0850 17
MIDI Optimizer F/R EQ10-T13	1/2	35 l/s	Turbo 13 mm	ErgoQIC 10	No	8202 0850 04
MIDI Optimizer F/RD EQ10-T13	1/2	35 l/s	Turbo 13 mm	ErgoQIC 10	Yes	8202 0850 13